

HAMILTON-SOUTHEASTERN UTILITIES, INC.

DESIGN SPECIFICATIONS
FOR
SANITARY SEWER FACILITIES

The ideas, designs, drawings and concepts contained herein are the exclusive intellectual property of Sanitary Management & Engineering Company, Inc. and are not to be used or reproduced in whole or in part, without the written consent of Sanitary Management & Engineering Company, Inc.

SECTION 1 - GENERAL.....	1
1.01 - Definitions	1
1.02 - Purpose	2
1.03 - Applicability	3
1.04 - Liability and Costs for Project.....	3
1.05 - Specifications and Details Sheets	3
1.06 - Drawing Discrepancies and Omissions	3
1.07 - Governing Laws, Codes and Regulations.....	4
1.08 - Initiation of Construction.....	4
1.09 - Notices	5
1.10 - Completion Documentation.....	5
1.11 - Confined Space Entry	5
SECTION 2 - GENERAL PROCEDURES	6
2.01 - Contract	6
2.02 - Fees	6
2.03 - Affected Party	6
2.04 - Waste Load Allocation Letter.....	6
2.05 - Approved Contractors.....	7
2.06 - Inspection.....	7
2.07 - Testing	7
2.08 - Private Sewer Facilities	7
2.09 - Pre-construction Meeting.....	8

SECTION 3 - EASEMENTS AND DEEDS	8
3.01 - Platted Easements	8
3.02 - Off-site Easements.....	9
3.03 - Minimum Easement Width.....	11
3.04 - Additional Easements	11
3.05 - Easements or Right-of-Ways Granted to Other Entities.....	12
3.06 - Deeds for Lift Stations.....	12
SECTION 4 - COVENANTS AND RESTRICTIONS	12
4.01 - Standard Requirements.....	13
4.02 - Conditional Requirements	13
4.03 - Declaration of Sanitary Sewer Restrictions	14
4.04 - Review	14
SECTION 5 - MASTER PLANNING	14
5.01 - Service Area.....	14
5.02 - Service to Adjoining Parcels	15
5.03 - Design Considerations	15
SECTION 6 - DESIGN REQUIREMENTS	16
6.01 - Vertical Datum	16
6.02 - Improvements to Downstream Sanitary Sewer Facilities.....	16
6.03 - Size	18
6.04 - Slope	18
6.05 - Cover	19
6.06 - Materials of construction	20
6.07 - Buoyancy	22
6.08 - Sanitary Sewer Manholes	22
6.09 - Laterals	29
6.10 - Force Mains and Common Force Mains	32
6.11 - Lift Stations, Grinder Pumps and Effluent Pumps	36
6.12 - Separation from Buildings and Structures.....	39
6.13 - Separation from Water Supplies.....	39
6.14 - Utility Separation and Utility Crossings.....	41
6.15 - Street Separation and Street Crossings.....	42
6.16 - Storm Sewers, Field Tiles and Water Ways	42
6.17 - Landscaping, Retaining Walls, Lighting, Fencing, Signs, etc.	43
6.18 - Bores	44
6.19 - Future Land Use	44
6.20 - Compliance.....	45
SECTION 7 - CONSTRUCTION PLAN DOCUMENTATION	45
7.01 - Permits	45
7.02 - General.....	46
7.03 - Primary Plats.....	47
7.04 - Secondary Plats.....	48

7.05 - Title sheet	48
7.06 - Site Development Plan	48
7.07 - Sanitary Sewer Plan and Profiles (Gravity and Force Main).....	52
7.08 - Lift Station Plan Sheet	62
7.09 - Storm Sewer Plan and Profile Sheets	63
7.10 - Detail and Specification Sheets	63
7.11 - Shop Drawings	64
7.12 - Architectural Plans	64
7.13 - Landscaping, Site Lighting and Other Related Plans	65
7.14 - Revisions	66
7.15 - Construction Plan Approval	67
7.16 - Record Drawings	67
SECTION 8 - IMPROVEMENT LOCATION PERMITS (“ILP”)	67
8.01 - General Requirements	67
8.02 - Architectural Requirements	68
8.03 - EDU Calculation.....	69
8.04 - Existing Buildings/Structures and the Connection of Existing Sewers.....	70
8.05 - Sources of Contamination	71
8.06-Pools	71

EXHIBIT A: Common Lateral Detail

SECTION 1 - GENERAL

1.01 - Definitions

For the purpose of these Design Specifications for Sanitary Sewer Facilities (“Design Specifications”), the following definitions shall apply:

- A. “HSE” shall mean Hamilton Southeastern Utilities, Inc., the public utility which provides sanitary sewer service in the Project (as hereafter defined) area. HSE’s address is 11901 Lakeside Drive, Fishers, Indiana 46038, and HSE’s phone number is (317) 577-2300.
- B. “Engineer” shall mean the engineer for HSE, which is Sanitary Management & Engineering Company, Inc. (“SAMCO”) or SAMCO’s engineers. SAMCO’s inspector shall be the Engineer’s representative during construction of the Project. SAMCO’s address is 11905 Lakeside Drive, Fishers, Indiana 46038, and SAMCO’s phone number is (317) 577-1150.
- C. “Subscriber” shall mean those signatories identified as Subscribers under a Special Contract for Extension of Sewer Mains and Facilities with HSE through which the Project is being undertaken. Subscriber is generally the Owner under a construction contract. This definition is intended to include all employees, sub-contractors and/or agents acting in the interest of Subscriber.
- D. “Contractor” shall mean any construction contractor approved by HSE to construct, install, maintain, repair and remove public or private sanitary sewer facilities within the HSE service area. This definition is intended to include all employees, sub-contractors and/or agents acting for or on behalf of the Contractor’s company.
- E. “Design Engineer” shall mean the engineer sealing the Construction Plans, as opposed to the Engineer for HSE and the Record Drawing Engineer, both of whom are also defined under these Design Specifications. This definition is intended to include all employees, sub-contractors and/or agents acting for or on behalf of the Design Engineer’s company.
- F. “Record Drawing Engineer” shall mean the engineer who will certify the record drawings, as opposed to the Engineer for HSE and the Design Engineer, both of whom are also defined under these Specifications. The Record Drawing Engineer and Design Engineer may be the same person or represent the same company. This definition is intended to include all employees and/or agents acting for or on behalf of the Record Drawing Engineer’s company.
- G. “Project” shall mean any sanitary sewer facilities constructed within the service area of HSE and shall include all work necessary for the installation of all sanitary sewer infrastructure and appurtenances in conformity with HSE approved construction drawings and the standards, specifications and details of HSE.

- H. “Conveyed” with regards to sanitary sewer facilities means Projects for which HSE has received title.
- I. “Private” with regards to Projects shall mean Projects from which sewage flows into HSE’s sanitary sewer facilities, but for which title for the sanitary sewer facilities is not to be Conveyed to HSE.
- J. “Completed” with regards to Projects shall mean any Projects which are acceptably constructed, tested and through which customer service has been authorized by HSE. All applicable fees must be paid to HSE prior to a Project being deemed Completed.
- K. “Construction Plans” shall mean primary plats, secondary plats, sets of construction drawings, architectural plans, shop drawings, landscaping plans, record drawings, easements, deeds, covenants and restrictions and any other documentation to be submitted under these Design Specifications. Construction Plans must meet the applicable standards in effect at the time the documents are submitted.
- L. “Completion Documentation” shall mean record drawings and other documentation to be submitted under HSE’s “Sanitary Sewer Completion Specifications”. Completion Documentation must meet the applicable standards in effect at the time the documents are submitted.
- M. “EDU” shall mean Equivalent Dwelling Unit. One EDU equals 300 gallons per day which is the anticipated water usage of one residence in HSE’s service area.
- N. “Ultimate Depth” as it pertains to separation distances shall mean the greatest depth of cover from the invert of the pipe to grade, whether constructed initially or increased by additional fill placed in the future.

1.02 - Purpose

The purpose of these Design Specifications is to define the standards for engineering design, preparation of construction drawings and plats, construction specifications and easements related to the Project which will allow for the orderly and proper installation of sanitary sewer facilities constructed within HSE’s service area.

These Design Specifications presumes its user will possess a basic understanding in the area of civil engineering design, construction, or land alteration. Readers of these Design Specifications who are not qualified by education or experience should consult with a more qualified person or persons possessing professional expertise in one or more of these fields prior to application of the requirements set forth herein.

1.03 - Applicability

These Design Specifications are applicable for all public and private sanitary sewer facilities which will be connected to HSE's sanitary sewer system. This includes Private Projects which will not initially be connected to HSE's sanitary sewer system but at some future date may be connected to the system.

1.04 - Liability and Costs for Project

No direction, field directive or other instruction contemplated by these Design Specifications and/or conducted by others shall accrue any liability, charge or cost to HSE, Engineer or Engineer's inspectors. *The Utility will not assume responsibility for noncompliance with the referenced specifications as a result of information not provided in these Specifications.*

1.05 - Specifications and Details Sheets

- A. HSE's Gravity Sanitary Sewer Details sheet, Sanitary Sewer Specifications sheet, Horizontal Bore Specifications sheet, Duplex/Initial Triplex/Triplex Lift Station Plan sheets, Initial Triplex/Triplex Lift Station Electrical Diagram sheets, Lift Station and Force Main Details sheet, Lift Station and Force Main Specifications sheets, Standards for Design and Construction of Laterals, Rules and Regulations, Master Plan and Sanitary Sewer Completion Specifications are integral parts of these Design Specifications. The Design Engineer should become familiar with these documents prior to the initiation of any sanitary sewer facility design to be constructed within HSE's service area.
- B. These Design Specifications and HSE's Master Plan and other standards, specifications and details are complementary in nature and should not be interpreted individually.
- C. These Design Specifications and HSE's Master Plan and other standards, specifications and details are subject to revision at any time. Any changes that may occur during design of the Project must be incorporated before approval. These documents are also subject to revision at any time during construction when, in Engineer's opinion, those revisions materially affect the maintenance, operation or life of the Project. All such revised documents must replace the corresponding documents in the construction drawings.
- D. HSE reserves the right to modify or waive any of these Design Specifications and/or its Master Plan and other standards, specifications and details in its best interest.

1.06 - Drawing Discrepancies and Omissions

- A. Design Engineer must notify Engineer of any conflicts between these Design Specifications and HSE's Master Plan and other standards, specifications and details. Resolution of any such conflict shall be at the Engineer's sole discretion.

- B. Any design requirements which are not covered in these Design Specifications or HSE's other standards, specifications and details, but are required for construction of this Project, must be approved by Engineer prior to approval of the construction drawings.

1.07 - Governing Laws, Codes and Regulations

- A. Plans, including professional certification, scales, north arrows, capacities, design requirements and other engineering details must meet all applicable laws, codes or regulations and be in accordance with the requirements of all governmental agencies and public entities having jurisdiction.
- B. These Design Specifications shall not be considered as a substitute, nor shall they supersede any state or federal law, code or regulation related to the design. In the event of a conflict between any state or federal law, code or regulation governing the design and these Design Specifications, the more stringent requirement will apply.
- C. All persons on site must abide by all Indiana Occupational Safety and Health Administration ("IOSHA") standards including but not limited to "General Construction Practices" and "Trench Safety Standards".

1.08 - Initiation of Construction

- A. Plan approval will be an authorization to proceed with construction of the Project, however, it shall not be construed as authority to violate, cancel or set aside any of HSE's requirements or the laws, codes, regulations and permit processes of governmental agencies or public entities. Approval will be evidenced by an "Approved Hamilton Southeastern Utilities, Inc." stamp on the construction drawings.
- B. Plan approvals will be valid for a period of six (6) months from the date of the approval stamp. Extensions of this time limit may be requested from Engineer if extenuating circumstances exist. Engineer's decision regarding time extensions will be final.
- C. Prior to the start of construction, Design Engineer must receive formal written approval from Engineer. At this time, Design Engineer must supply Engineer with five (5) complete sets of construction drawings for distribution to the Engineer's inspectors and approved Contractor.
- D. Contractor will not be permitted to initiate construction until the construction drawings are formally approved and the Subscriber has entered into all necessary agreements and authorizations with, and all required fees have been paid to, HSE.
- E. Contractor will not be permitted to initiate construction until all applicable permits have been

obtained from and approved by all affected government agencies and public entities. Copies of the permits must be submitted to Engineer for review.

- F. Contractor will not be permitted to initiate construction until all off-site easements have been reviewed, approved and recorded by Engineer.

1.09 - Notices

All notices required by these Design Specifications must be given to both HSE and Engineer at their respective business offices.

1.10 - Completion Documentation

- A. HSE's "Sanitary Sewer Completion Specifications" specify the requirements which must be met prior to the time the Project is placed into service.
- B. Contractor and Record Drawing Engineer must provide to HSE and Engineer in Subscriber's name the necessary Completion Documentation for the Project, including record drawings and a digital file. At the end of construction, Engineer will provide a Record Drawing Notification to the Subscriber and Record Drawing Engineer. Completion Documentation, including record drawings in a digital format, must be delivered by Contractor and Record Drawing Engineer in the name of Subscriber to Engineer within thirty (30) days of the date of this notification. If the Completion Documents have not been provided within sixty (60) days of the date of this notification, HSE will procure the services necessary to generate or otherwise acquire the record drawings and other Completion Documentation at Subscriber's expense.
- C. Contractor must submit a HSE Lateral Location form detailing all wye connections, to Engineer, on a daily basis. The Lateral Location form identifies the as-built wye station, direction, lot serviced and length of all sewer lateral connections. The as-built location of the wye station can be supplied by measuring along the pipe section and assigning a station to each connection from the nearest downstream manhole. An accuracy of two (2) +/- feet is required.
- D. Record Drawing Engineer must also submit Sanitary Sewer Record Drawing Information sheets for all manhole structures which have not been previously as-built. These sheets must be submitted to Engineer within fourteen (14) days of the Record Drawing Notification.

1.11 - Confined Space Entry

All persons, including but not limited to Subscribers, Contractors, sub-contractors, Design Engineers, Record Drawing Engineers and surveyors must abide by HSE's "General Procedure for Manhole Opening and Entry" or the most recent IOSHA confined space entry standards, which ever is more stringent.

SECTION 2 - GENERAL PROCEDURES

2.01 - Contract

Subscriber must enter into an agreement with HSE to provide sanitary sewer service to the Project. A contract will need to be signed with HSE prior to Engineer reviewing the Construction Plans and issuing formal comment review letters on the Project.

2.02 - Fees

A. Preliminary Plan Review (“PPR”).

PPR will need to be paid to HSE prior to Engineer reviewing the Construction Plans and issuing formal comment review letters on the Project.

B. Contribution.

C. Connection.

D. Inspection.

E. Subsequent Connectors (If Applicable).

F. Contact HSE with questions regarding monthly fees and fee structure for surcharge of high strength effluent.

2.03 - Affected Party

A. HSE and Engineer must both be listed as an affected party on the Indiana Department of Environmental Management (“IDEM”) permit applications for all Projects within HSE’s service area.

B. When connecting into a sanitary sewer controlled by an entity other than HSE (For example, the Town of Fishers), that party must be listed as an affected party on the IDEM permit application.

2.04 - Waste Load Allocation Letter

HSE will not issue the IDEM waste load allocation letter until the following:

A. A contract is signed with HSE.

B. PPR fees have been paid to HSE.

- C. An Indiana Department of Environmental Management “327 IAC Article 3 Construction Permit – Sanitary Sewer Design Summary Form” is submitted by the Design Engineer to HSE.

2.05 - Approved Contractors

- A. An HSE approved Contractor must construct all main line sanitary sewer facilities, including Private sanitary sewer facilities.
- B. An HSE approved lateral Contractor must construct all laterals, including Private sanitary sewer facilities.
- C. *All HSE approved Contractor foreman and pipe layers are subject to an annual review to demonstrate a capable aptitude of the HSE specification requirements.*

2.06 - Inspection

- A. An Engineer’s inspector must be present at all times for construction inspection of all sewer facilities, including Private sanitary sewer facilities. For requirements regarding the inspection of gravity sanitary sewer mains refer to HSE’s Gravity Sanitary Sewer Specifications, force mains refer to HSE’s Lift Station and Force Main Specifications and laterals refer to HSE’s “Standards for Design and Construction of Laterals”.
- B. To schedule inspections of *mainline sewers and force mains*, contact HSE a minimum of fourteen (14) days prior to the initiation of construction. Contractor must schedule a pre-construction meeting with the Engineer prior to construction.
- C. *To schedule inspections of lateral hookups, contact HSE a minimum of 72 hours prior to initiation of construction. See “Standards for Design and Construction of Laterals” for additional requirements that must be met at that time.*
- D. All sanitary sewer facilities, including Private sanitary sewer facilities, will be assessed inspection fees.

2.07 - Testing

All sanitary sewer facilities, including Private sanitary sewer facilities, will be tested in accordance with procedures outlined on either HSE’s Standard Sanitary Sewer Specifications sheet, Horizontal Bore Specifications sheet, or Lift Station and Force Main Specifications sheet.

2.08 - Private Sewer Facilities

- A. All applicable fees, including Preliminary Plan Review, Availability, Connection, Inspection and Subsequent Connectors fees will need to be paid to HSE.
- B. Easements granted to HSE are not required for Private sanitary sewer facilities; however, the Subscriber may need to obtain off-site easements in favor of the Subscriber for the construction, operation, inspection, maintenance, reconstruction, and removal of sanitary sewer facilities. The off-site easements will be required to maintain Minimum Easement Width as described in the Easements and Deeds section of these Design Specifications.
- C. Engineer may request easements to the property boundary for future service to adjoining parcels.
- D. HSE will require an agreement regarding ingress/egress rights for the inspection and maintenance of Private sanitary sewer facilities.
- E. All Private sanitary sewer facilities must be designed, constructed, inspected and tested in accordance with these Design Specifications and HSE's other standards, specifications and details. Design Engineer may request a variance on certain design requirements; however, Engineer's decision regarding variances will be final.
- F. Record drawings in accordance with HSE's Sanitary Sewer Completion Specifications will be required for Private sanitary sewer facilities.
- G. If at some point in the future the Subscriber wishes to Convey Private sanitary sewer facilities to HSE, then the Engineer will need to perform a study, including inspection and testing, to determine compliance with all of HSE's requirements. If the sanitary sewer facilities do not comply with the requirements, then HSE may deny Conveyance until the system has been repaired or upgraded to conform to HSE's requirements. Subscriber shall reimburse HSE for Engineer's fees to perform the study.

2.09 - Pre-construction Meeting

Design Engineer may be required to attend a pre-construction meeting with the Contractor, Engineer's inspector, construction manager, Engineer, Subscriber and any other affected party to discuss construction issues relative to the Project.

SECTION 3 - EASEMENTS AND DEEDS

3.01 - Platted Easements

- A. All sanitary sewer facilities which will be Conveyed must be constructed within land platted or recorded as a sanitary sewer or utility easement or land to be deeded to HSE. At Engineer's discretion, sanitary sewer facilities may be constructed within public right-of-way

with written approval from the appropriate governmental agency.

- B. The definition of sanitary sewer and utility easements must allow for the construction, extension, operation, inspection, maintenance, reconstruction, and removal of sanitary sewer facilities and give HSE the right of ingress/egress. If the plat includes sanitary sewer and utility easements, the definition of utility easements must also include the uses specified in sanitary sewer easements.
- C. Easements may be requested to provide sanitary sewer service to adjoining parcels. These easements may be in the form of standard sanitary sewer/utility easements or easements “in favor” of an adjoining parcel. Depending on the site specific conditions, Engineer will determine the appropriate easement type.

3.02 - Off-site Easements

- A. All off-site sanitary sewer facilities will need to be constructed in a sanitary sewer easement. Sanitary sewer facilities will be considered off-site unless they will be contained within a platted sanitary sewer or utility easement **immediately** following construction Completion.
- B. It will be the responsibility of the Design Engineer to identify and notify Engineer of any gaps or overlaps. Depending on the route of the sanitary sewer facilities, a route survey may need to be prepared to prevent gaps between dedicated easements.
- C. Engineer will determine the appropriate easement type. For example, metes and bounds, route survey, etc.
- D. HSE’s standard sanitary sewer easement agreements must be utilized. A fully completed (including name **and** address of grantor) and executed agreement must be submitted to Engineer for review **and** approval prior to being recorded. Engineer will record all easements granted to HSE. Easements granted to HSE that have not been reviewed and approved may need to be re-recorded.
- E. A copy of the current deed for all parcels over which the easement is to be granted must be submitted with the easement documentation (legal description and drawing). If the current deed is not a Warranty deed or other extenuating circumstances exist (Land Contract, Affidavit of Survivorship, etc.) additional deeds may be required. In these instances contact Engineer for clarification.
- F. A copy of the current land title survey for all parcels over which the easement is to be granted must be submitted with the easement documentation.
- G. A legal description prepared as follows must be submitted with the easement documentation:

- 1) Labeled as "Exhibit A".
 - 2) Contain all appropriate controlling calls. Controlling calls are required to minimize problems with gaps or overlaps.
 - 3) Design Engineer shall also consider the appropriate basis of bearings.
- H. A standard scale (1"=50', 1"=100', etc.) drawing of the legal description labeled "Exhibit A" must be submitted. The drawing will be recorded with the easement agreement, however it must be prepared as a stand-alone document on legal or letter size paper. The drawing must provide the following:
- 1) Complete name of property owner(s) and other affected parties (For example, properties under a land contract, etc.).
 - 2) Type of document (Warranty Deed, Quitclaim Deed, Land Contract, etc.) for current property owner(s) and other affected parties with instrument numbers.
 - 3) Commencement point and commencement calls.
 - 4) Point of Beginning.
 - 5) North arrow and scale.
 - 6) Bearings and distances.
 - 7) Section corners and section lines.
 - 8) Approximate location of all affected parcel lines with deed references.
 - 9) All other easements with instrument numbers.
 - 10) If the easement area is going to be identified on the drawing, then please cross hatch the area rather than shade the area. Shading does not Xerox clearly.
- I. The legal description and drawing must also include the following:
- 1) Signed and certified by an appropriately registered Indiana land surveyor.
 - 2) For metes and bounds descriptions, the calculated closure of the description must be within 0.03 +/- feet.
 - 3) Sheet numbers in the form of "Sheet 1 of 2," "Sheet 2 of 2," etc.
 - 4) Indicate a revision date.
 - 5) Comply with the requirements of the Hamilton County Recorder's Office.
- J. Copies of additional deeds (Adjoiner's deed, Land Contract, Affidavit of Survivorship, etc.), referenced documents (Land Title Surveys, State Highway construction plans, etc.), other utility easements across the affected parcels, etc. must be submitted with the easement documentation.
- K. Encroachment agreements when crossing existing exclusive utility easements or right-of-ways, legal drains, railroads, etc. must be submitted with the easement documentation.
- L. Sanitary sewer facilities not constructed adjacent to a public right-of-way may, at HSE's discretion, require ingress/egress easements. The means of access and easement width will be determined on a case by case basis.

- M. Engineer will make the determination as to the type of sanitary sewer easement agreement. Early coordination is recommended to eliminate delays during the Construction Plan approval process.

3.03 - Minimum Easement Width

- A. The minimum easement width is based on the Ultimate Depth (from invert to grade) of the sanitary sewer facilities as follows:

<u>Depth of Sewer</u>	-	<u>Easement Width</u>
Up to 15 feet	-	20 feet
15 to 20 feet	-	25 feet
20 to 25 feet	-	30 feet
25 to 35 feet	-	40 feet
Over 35 feet	-	Case by case basis

- B. Larger easement widths may be required based upon soil/groundwater conditions and Master Plan issues.
- C. Where possible, all sanitary sewer facilities shall be centered in the easement. If it is not possible to center the sewer within an easement, the minimum separation between the centerline of the sanitary sewer facilities and the edge of the easement must be at least one-half of the easement width required at that depth.
- D. For sanitary sewers twenty-four (24) inches and larger the easement width will be determined on a case-by-case basis, but shall not be less than a minimum of fifty (50) feet in width.
- E. Based on the as-built location of sanitary sewer facilities, Engineer may request additional easements to comply with the required minimum horizontal separation distances (from edge of easement to center of sanitary sewer facilities) versus Ultimate Depth (from invert to grade). To avoid requests for additional easements, Engineer recommends the following:
- 1) Subscriber and Design Engineer may wish to grant wider easements.
 - 2) Prior to recording the plat and based upon the as-built location/depth of sanitary sewer facilities, Design Engineer should review the minimum horizontal separation distances and adjust the easements accordingly.

3.04 - Additional Easements

- A. HSE reserves the right to require additional easements due to the configuration of the sanitary sewer facilities and/or the development.

- B. Sanitary sewer facilities not constructed adjacent to a public right-of-way may, at Engineer's discretion, require ingress/egress easements. The means of access and easement width will be determined on a case by case basis.
- C. Wider easements may be required for the installation of an access drive. For example, at all angle breaks in the route of the sanitary sewer facilities.
- D. Temporary or permanent easements may be required for specific issues related to construction or maintenance of the Project. For example, storage of materials and accessibility of construction equipment.

3.05 - Easements or Right-of-Ways Granted to Other Entities

- A. HSE will request copies of proposed/existing easements and right-of-ways crossing over sanitary sewer facilities or contained within the boundary of the Project.
- B. HSE may request encroachment agreements from entities impacted by the construction of a Project. Generally, encroachment agreements will be requested when the entity has been granted a previously recorded exclusive easement.

3.06 - Deeds for Lift Stations

- A. Prior to Completion, a **Warranty** Deed granted to HSE is required for all lift stations. The legal description and drawing shall be prepared as described in Off-site Easements of this section of these Design Specifications.
- B. A sanitary sewer easement that adjoins the lift station parcel will also need to be granted to HSE.
- C. The lift station parcel and surrounding easement must be of adequate size to allow for full excavation of the lift station considering that the excavated material will need to be stored on the lift station parcel according to the "Storage Capacity (In Tons) of Cone- or Tent- Shaped Stockpiles of Sand or Gravel" table described in the Highway Extension and Research Project for Indiana Counties and Cities ("HERPICC"), "Job Guide."
- D. Engineer will approve the size of the deeded parcel and surrounding easement.
- E. After construction is Completed, Design Engineer will be required to monument (capped rebar) the lift station property corners.

SECTION 4 - COVENANTS AND RESTRICTIONS

4.01 - Standard Requirements

The following comments must appear in the *Declaration of Sewer Restrictions and recorded against the deed of the property*:

- A. “All sanitary sewer and utility easements may be used for the construction, extension, operation, inspection, maintenance, reconstruction and removal of sanitary sewer facilities and provide Hamilton Southeastern Utilities, Inc. the right of ingress/egress.” **Note:** If the covenants include a separate description of sanitary sewer and utility easements, the definition of utility easements must also include the phrase “... as well as for the uses specified in sanitary sewer easements.”
- B. “Pavement or concrete, including driveways and sidewalks, shall not be constructed on or within one (1) foot horizontal distance of any sanitary sewer castings.”
- C. Owner *may* place or permit to be placed any trees or other deep rooted landscaping *with separation as specified in the current (at the time of planting) HSE Approved Tree List. For trees not listed in the HSE Approved Tree List a minimum separation of ten (10) foot horizontal distance for Laterals or any other sanitary sewer facilities (as measured from the drip line of the mature tree to the center of sanitary sewer facilities) must be maintained.* Any trees or landscaping placed within easements or right-of-ways are at risk of being damaged or removed by HSE without the obligation of replacement.
- D. “No mounding, lighting, fencing, signs, retaining/landscaping/entrance walls, irrigation lines, *drives/paths*, etc. shall be placed within ten (10) feet of the center of the sanitary sewer infrastructure. Any of the above listed items placed within easements or right-of-ways is at risk of being removed by utilities without the obligation of replacement.”
- E. “All homeowners not serviced by gravity sanitary sewer service are responsible for all maintenance, repair and replacement of all grinder/ejector pumps, force mains and gravity laterals from the residence to its connection to the sanitary sewer main.”
- F. “The discharge of clear water sources (foundation drains, sump pumps, roof drains, etc.) to the sanitary sewers is prohibited.”
- G. “Grade changes across sanitary sewer facilities must be approved in writing by Hamilton Southeastern Utilities, Inc.”
- H. All laterals constructed are private and are to be maintained by the property owner.

4.02 - Conditional Requirements

The following comments must appear in the *Declaration of Sewer Restrictions and recorded against the deed of the property* when the described condition exists:

- A. "Hamilton Southeastern Utilities, Inc. its successors or assigns are granted the right of ingress/egress over and across all paved or concrete surfaces." **Note:** This comment needs to appear for all Projects except single family residential subdivisions.
- B. "The Homeowner's Association will be responsible for all repairs to decorative (surfaces other than broom finished concrete or asphalt) private streets due to construction or maintenance of the sanitary sewer facilities." **Note:** This comment needs to appear when private (not maintained by the Town of Fishers, City of Noblesville or Hamilton County Highway) streets are constructed.
- C. "Hamilton Southeastern Utilities, Inc. will not be responsible for the operation, maintenance and replacement of the lateral servicing (provide lot or building number) from the building to its connection into the gravity main." **Note:** This comment needs to appear when laterals are installed in sanitary sewer or utility easements under large paved areas, including parking lots, driveways, etc.

4.03 - Declaration of Sanitary Sewer Restrictions

If the Subscriber does not record covenants and restrictions for a Project, then a Declaration of Sewer Restrictions must be recorded. This document will include the required covenants and restrictions for sanitary sewer facilities. Contact Engineer for a copy of this document.

4.04 - Review

In an effort to eliminate amendments, HSE recommends that Engineer review the covenants and restrictions of each Project prior to them being recorded.

SECTION 5 - MASTER PLANNING

5.01 - Service Area

Sanitary sewer facilities must be designed to serve the anticipated flows from the entire upstream service area. When service will be extended beyond a Project, the Design Engineer may be requested by Engineer to provide the following:

- A. A drawing or map indicating the upstream service area for which the Project's sanitary sewers are designed to service. *A preliminary layout to scale of the upstream service area shall be shown. The layout is to be plotted at one of the following scales: 1"=10', 20', 30', 40', 50', 60', or 100' and include pipe size, and manhole's Top of Casting and invert elevations.* The service area will generally follow parcel boundaries and drainage sheds. However, in certain drainage sheds, Engineer has performed detailed master planning which

indicates the anticipated service route of particular parcels. Design Engineer should refer to HSE's most current master plan for further information and request relevant information from Engineer.

- B. Calculations of the upstream service area with all applicable lift station connections from other drainage sheds (in acres), developable/flood plain area (in acres), anticipated developed density (EDU's per acre and total EDU's) and anticipated flows (average flows in gpm, peaking factor, and peak instantaneous flows in gpm if anticipated to be different from peaking factor).

5.02 - Service to Adjoining Parcels

- A. Sanitary sewer facilities must be designed to accommodate the connection of all future subdivision sections and/or unsewered parcels within the service area. Sanitary sewer facilities must be designed to the boundaries of a Project when future extensions are anticipated.
- B. It will be the responsibility of the Subscriber to extend interior sanitary sewer facilities to the boundary of the development for future service to adjoining properties as directed by Engineer.
- C. HSE does not allow lateral connections to a sewer beyond those installed during original construction. Therefore, consideration of future connections must be addressed in the design process. *Two existing homes may be served by a single lateral extension terminating as per common lateral detail. (See exhibit A)*
- D. Easements may be requested to provide sanitary sewer service to adjoining parcels.

5.03 - Design Considerations

- A. Gravity sanitary sewers that will be extended in the future must connect to the existing manhole at the lowest possible elevation and extend upstream at substantially minimum grade. Substantially minimum grade means the design grade acceptable to the Design Engineer and Engineer which will provide adequate tolerance so that the gravity sewer will be capable of being constructed at or near minimum grade as specified in Slope under the Design Requirements section of these Design Specifications.
- B. *No more than four (4) connections to existing manholes, three (3) incoming and one (1) outgoing, will be allowed. Connections to existing manholes will be evaluated on a case-by-case basis to determine if rehabilitation will be required. Rehabilitation methods will be determined on a case-by-case basis. Connections must meet separation requirements per section 6.08J.*

- C. Sanitary sewer facilities constructed near waterways must be designed at an adequate depth that allows gravity access across the waterway to the opposite side. Gravity access must be designed to maintain adequate separation (from the bottom of the waterway) as specified in Storm Sewers, Field Tiles and Water Ways under the Design Requirements section of these Design Specifications.
- D. HSE prefers not to install laterals on sewers deeper than twenty (20) feet. Therefore, Design Engineer shall contact Engineer to discuss alternatives. For example, a parallel shallow sewer, special lateral construction, etc. may be required.

Section 6 - DESIGN REQUIREMENTS

These design requirements are applicable to gravity sewers, force mains and lift stations.

6.01 - Vertical Datum

- A. All sanitary sewer facilities must be designed based upon an HSE approved vertical control monument on a vertical datum of NAVD 1988. Vertical control monuments are detailed in HSE's "Horizontal and Vertical Control Data" which is available upon request from Engineer. If a vertical control monument is not within one (1) mile of the Project, then contact Engineer to discuss the appropriate vertical datum.
- B. Engineer may grant exceptions to this standard in writing.
- C. Engineer will make the determination as to the basis of vertical datum for the sanitary sewer facilities. Early coordination is recommended to eliminate problems/delays during the Construction Plan approval process.

6.02 - Improvements to Downstream Sanitary Sewer Facilities

- A. Engineer will make the determination as to the need for improvements to downstream sanitary sewer facilities. Early coordination is recommended to eliminate delays during design.
- B. *Engineer will evaluate the downstream capacity of the receiving sanitary sewer. The Engineer will rely upon the following:*
 - 1) Available Data/Information including the following:
 - (a) *Existing flow monitoring data*
 - (b) *Sanitary sewer studies*
 - (c) *Maintenance records*
 - (d) *Complaint records*

- (e) *Past and/or proposed projects*
 - (f) *Any other information deemed relevant by the Engineer*
- 2) Additional Data/Information may be required from the applicant if the Available Data/Information is not adequate to make an informed decision on the adequacy of the downstream facilities. The necessary task will be conducted at no cost to the utility. Such task may include the following:
- Temporary monitors*
- (a) *The complexity of the downstream system will determine number required.*
 - (b) *The monitoring duration shall be a minimum of sixty (60) days or until two (2) one (1) inch of rainfalls in a 24-hour period is recorded, whichever is the greater period of time.*
 - (c) *If possible, part of the monitoring period shall be done during the months of March, April, May, and June. However if monitoring cannot be done during those months, the Engineer will consider an alternate time period.*
 - (d) *Monitoring shall not be done during the month of January.*
 - (e) *Temporary rain gages shall be installed at or near the temporary flow monitoring site(s) during the flow monitoring period unless the monitors are located within one-half (1/2) mile of an operating utility rain gage.*
 - (f) *Flow Monitoring Data and Format shall include the following as a minimum:*
 - i. *Depth/Velocity Hydrographs*
 - ii. *Flow Hydrographs*
 - iii. *Scatterplots / Scattergraphs*
 - iv. *Any other data deemed necessary*
 - (g) *Other requirements as deemed necessary*
- 3) Hydraulic Modeling-The Engineer may require the extension of the utilities existing sanitary sewer collection system model to the point of connection of the proposed development. If a Model extension is necessary, the SWMM Model shall be used. To assure consistency, the Model shall be coordinated with the consultant currently being used by the utility.
- 4) Lift Station System Evaluation-The Engineer may require an evaluation of one or more lift station systems. The evaluation may include the following systems:
- (a) *Hydraulic*
 - (b) *Electrical*
 - (c) *Mechanical*
 - (d) *Instrumentation & Control*
 - (e) *Others as deemed necessary*
- 5) Other evaluations as deemed necessary.

- C. *If the Engineer determines downstream capacity is not available for the proposed flow from the development, the Applicant has the following options:*
- 1) *Make additional capacity in the system, and/or*
 - 2) *Remove a sufficient volume of Infiltration/Inflow*
 - 3) *Connect to an alternate point within the sanitary sewer system. A downstream analysis of the alternate system may be required.*
- D. Improvements may include, but are not limited to, the following:
- 1) Upgrades and/or additions to the pumps, flow meters, controls and station piping of downstream lift stations.
 - 2) Installation of parallel force mains for downstream lift stations.
 - 3) Installation of *Neopoxy or Sprectrashield* coatings in manholes. For further information refer to Force Mains and Common Force Mains (Force Main Discharge) in this section of these Design Specifications.
 - 4) Installation of bolted and gasketed manhole castings. For further information refer to Force Mains and Common Force Mains (Force Main Discharge) in this section of these Design Specifications.
 - 5) Installation of odor control facilities. Contact Engineer for specific applications. For further information refer to Force Mains and Common Force Mains (Odor Control) in this section of these Design Specifications.

6.03 - Size

- A. Sanitary sewer facilities must be designed to serve the anticipated flows from the entire upstream service area. Subscriber shall contact Engineer to determine the applicability of over-sizing costs for each Project.
- B. No public gravity sewer will be less than eight (8) inches in diameter.
- C. No public force main will be less than four (4) inches in diameter, except in a common force main system.

6.04 - Slope

- A. HSE will not accept gravity sewers designed or installed below minimum slope as specified in Section 33.41 (Recommended Minimum Slopes) of Recommended Standards for Wastewater Facilities "Ten States Standards" (most recent Edition) and/or 327 IAC Article 3, whichever is more restrictive. It is strongly recommended that gravity sewers be designed at slopes greater than the minimum regulatory requirements. This additional slope allows the Contractor some leeway during construction.

- B. The minimum slope of end run gravity sewers shall be 1.00%. End run length shall be maximized to reduce the number of manholes. An end run sewer is defined as follows:
 - 1) The upstream manhole has no influent flows, and
 - 2) A sewer is not planned to be extended from the upstream manhole in the future.
- C. If a drop manhole can be constructed to avoid slopes greater than 5.00%, then HSE generally will require the drop manhole to be constructed.
- D. If Engineer permits gravity sewers to be designed at slopes greater than 5.00%, then Design Engineer must provide sealed calculations regarding a hydraulic jump in the downstream manhole. Design Engineer must provide calculations for design flow and also determine the flow rate at which the hydraulic jump would occur.
- E. Concrete restraining blocks keyed into the adjacent trench wall may be required for lines designed at slopes greater than 15.00%. Provide sealed calculations of the dimensions necessary for the restraining blocks with the Construction Plans. Contact Engineer for a standard detail to be incorporated into the plans if concrete restraining blocks are required.
- F. Force mains must be designed at a constant positive slope from low points and clean-outs to air/vacuum relief valves.

6.05 - Cover

- A. A minimum of five (5) feet of vertical cover must be maintained from grade to the crown of all gravity sanitary sewer facilities, including laterals and mains.
- B. The least amount of lateral cover is generally where the lateral crosses below the gutter of the street on the far side of the road. Engineer calculates lateral cover by assuming:
 - 1) The lateral invert elevation is the top of pipe elevation of the main line to which the lateral connects.
 - 2) The lateral is installed at 1.00%.
- C. A minimum of four and a half (4.5) feet of vertical cover must be maintained from grade to the crown of all force mains. Under no circumstances will vertical cover be permitted to be less than four and a half (4.5) feet.
- D. If adequate vertical cover can not be maintained on gravity sewers then:
 - 1) Concrete capping must be installed when cover is four (4) to five (5) feet. Refer to the Concrete Cap detail of HSE's Gravity Sanitary Sewer Details sheet for further information.
 - 2) Concrete encasement must be installed when cover is three (3) to four (4) feet.

Refer to the Concrete Encasement detail of HSE's Gravity Sanitary Sewer Details sheet for further information.

- 3) Under no circumstances will vertical cover be permitted to be less than three (3) feet.

- E. A minimum side cover of ten (10) feet (as measured horizontally from the sewer spring line) must be maintained from grade.

- F. If adequate side cover can not be maintained then:
 - 1) The side slope must be protected with gabions in accordance with Indiana Department of Transportation standards or a concrete retaining wall (design approved by HSE) must be installed when cover is six (6) to ten (10) feet.
 - 2) Under no circumstances will side cover be permitted to be less than six (6) feet.

6.06 - Materials of construction

- A. Based on the Ultimate Depth (from invert to grade) of the gravity sanitary sewers, the following types of pipe are to be used:

<u>Depth of Sewer</u>	-	<u>Pipe Type</u>
Up to 12 feet	-	PVC: ASTM D-3034 (SDR 35) ASTM F-679 (T-1, SDR 35, PS 46 or T-2**, SDR 35, PS 46) or PE: ASTM D3350 or AWWA C906 (DR11)
Up to 20 feet	-	PVC: ASTM D-3034 (SDR 26 or SDR 23.5) or ASTM D-2241 (SDR 21, PS 225 or greater) or AWWA C-900 (DR 18, PS 364 or greater) or AWWA C-905 (DR 25 or DR 18, PS 115 or greater) or PE: ASTM D3350 or AWWA C906 (DR11)
Up to 25 feet	-	AWWA C-900 (DR 18, PS 364 or greater) or AWWA C-905 (DR 18, PS 364 or greater) or PE: ASTM D3350 or AWWA C906 (DR11) <i>Ductile Iron Thickness Class 50 (6"-8"), Class 50 (10"-12"), Class51 (14"-16"), Class52 (18"-20"), Class 54 (24")</i>
Up to 35 feet	-	<i>Ductile Iron Thickness Class 50 (6"-8"), Class 52 (10"-12"), Class 53 (14"-16"), Class 55 (18"-20") and Class 56 (24")</i>
Over 35 feet	-	Contact Engineer

**The Engineer must approve the use of T-2 pipe in writing.

- B. *Upon request, the Design Engineer shall submit all calculations verifying the pipe selected is acceptable.*
- C. When a gravity sewer is constructed along the side yard of a lot then it must be installed as ductile iron pipe or PVC AWWA C-900 DR 18. PE pipe will be considered when used at a directional bore.
- D. *All PVC pipe must be manufactured and dated within six (6) months of the installation date and free from fading and discoloration.*
- E. PVC pipe possessing the following defects may be rejected for installation: variation from straight centerline; elliptical shape; illegible markings as required; deep or excessive gouges or scratches of the pipe wall; fractures, punctures, or cracks passing through the pipe wall; and damaged ends where such damage would prevent making a satisfactory joint.
- F. All field cutting of pipe shall be done in a neat, trim manner without overlap using a hand or power saw, and the cut end shall be beveled using a file or wheel to produce a smooth bevel of approximately 15deg. and be a minimum depth of one third (1/3) the pipe wall thickness or beveled as specifically recommended by the pipe manufacturer. Field cut pipe will only be installed at manholes, at prefabricated tees and wyes, and at the connection of new sanitary sewer to existing sanitary sewer.
- G. *Vitrified Clay Pipe (VCP), Reinforced Concrete Pipe (RCP), Truss and Closed Profile Large Diameter PVC Pipe for gravity sewer construction is not permitted.*
- H. Pipe blue in color shall not be used to avoid confusion with water pipes.
- I. When a gravity sewer connects into a drop manhole or lift station, ductile iron pipe must be installed from the drop manhole or lift station to an area of undisturbed earth. The length of ductile iron pipe will be dependent on soil conditions; however, a minimum length of twenty (20) feet is required. Refer to the Drop Manhole details of HSE's Gravity Sanitary Sewer Details sheet or Pumping Station Plan View detail of HSE's Duplex/Initial Triplex/Triple Lift Station Plan sheet for further information.
- J. Force mains must be constructed of PVC Pressure Pipe conforming to ASTM D-2241 (SDR 21 class 200) or AWWA C-900 (DR 18, class 150) - 4" to 12" diameter, PVC Pressure Pipe - Large Diameter conforming to AWWA C-905 (DR 18, class 235 or DR21, class 200) - 14" to 20" diameter), ductile iron class 51 - 4" diameter or ductile iron class 50 - 6" to 20" diameter or PE, when used at a directional bore.
- K. Force mains must be constructed of ductile iron pipe in the following situations. Depending

on the application the class of pipe may need to be increased.

- 1) Anticipated loading from vehicular traffic or other sources.
- 2) Ultimate Depth of cover greater than fifteen (15) feet.
- 3) Working pressure in excess of one hundred (100) psi.
- 4) Exposed piping in wet wells, valve vaults, manholes and other such structures.

L. Refer to the Separation from Water Supplies section of these Design Specifications for further information.

6.07 - Buoyancy

A. The buoyancy of sanitary sewer facilities must be incorporated into the design of a Project when high ground water conditions are anticipated.

6.08 - Sanitary Sewer Manholes

A. Separation

- 1) The maximum allowable distance between gravity manholes is five hundred (500) feet for sewers ten (10) inches in size or smaller.
- 2) The maximum allowable distance between gravity manholes is six hundred (600) feet for sewers twelve (12) inches in size or larger.

B. Location

- 1) Gravity manholes must be installed at the following:
 - (a) End of each stub, if greater than one hundred (100) feet.
 - (b) Changes in alignment.
 - (c) Changes in size.
 - (d) Changes in slope.
 - (e) At the intersection of all main line sewers.
 - (f) Engineer may require manhole with change of pipe type or material.
 - (g) *The number of manholes should be kept to a minimum and the Engineer may require a realignment to facilitate this.*
 - (h) *To minimize the potential for I/I, manholes shall NOT be designed or installed in any drainage path such as, but not limited to, the following locations:*
 - i. *Swales or ditches*
 - ii. *Roadside gutters*
 - iii. *Low points*
 - iv. *Adjacent to storm water inlets*
 - v. *Other areas the Engineer deems necessary.*
- 2) Pavement or concrete, including driveways and sidewalks, must not be constructed on or within one (1) foot horizontal distance of any sanitary sewer

casting.

- 3) Manholes can only be located where there is adequate drainage away from the structure to assure that flow will not occur over or into the manhole.
- 4) Where practical, manholes should be located on lot lines within subdivisions.
- 5) Manholes can not be located in the rear of a lot unless approved by Engineer and access must be provided as described in Sanitary Sewer Manholes (Access) of this section of these Design Specifications.
- 6) Manholes must be located to maintain minimum horizontal separations from utilities, streets, storm sewers, water ways, buildings, etc. as described later in these Design Specifications.
- 7) When extending a gravity sewer, manholes located near the boundary may be required to be removed and the gravity sewer extended as directed by the Engineer.

C. Access

- 1) All weather access drives must be provided for manholes that are not readily accessible (closer than one hundred (100) feet) from a public thoroughfare. Access drives must be constructed as follows:
 - (a) A minimum width of fourteen (14) feet.
 - (b) A minimum radius of forty-five (45) feet. *Design Engineer shall supply Engineer plots to scale with turning movements. Contact Engineer for minimum turning radius templates based on trucks to be used.*
 - (c) Centerline slopes can not exceed 5.00%.
 - (d) For centerline grade changes of greater than 2.00%, a twenty-five (25) foot vertical curve is required.
 - (e) The drive must have a crown with a side slope of 1/4" per foot.
 - (f) Shoulder side slopes must not exceed 3:1.
 - (g) Design Engineer must consider the impact to local drainage. Culverts may need to be installed, as surface drainage over the drive will not be permitted.
 - (h) Gates must be added for all fence crossings. The distance from the open face of the gate to right-of-ways must be a minimum of thirty-five (35) feet.
 - (i) HSE's Lift Station Access Drive detail must be included with the set of Construction Plans. Refer to HSE's Lift Station & Force Main Details sheet for a copy of this detail.
 - (j) HSE's Farm Gate detail must be included with the set of Construction Plans. Contact Engineer for a copy of this detail.
- 2) Grading (flat area with five (5) foot radius and side slopes of 3:1) around the structure must allow for the set-up of a tripod and winch. The tripod and

winch are required for confined space entry.

D. Protection

- 1) Pipe bollards will be required around all manholes that could be subjected to vehicular/farm traffic. Generally, pipe bollards will be required when manholes are located in an undeveloped area.
- 2) HSE's Bollard detail must be included with the set of Construction Plans. Contact Engineer for a copy of this detail.

E. Diameter

- 1) In general, the inside barrel diameter for manholes on sewers twenty-one (21) inches or smaller in size is four (4) feet.
- 2) In general, the inside barrel diameter for manholes on sewers twenty-four (24) inches or larger in size is five (5) feet.
- 3) Depending on the size, quantity and orientation of the connecting sewers, larger barrel diameters may be required.
- 4) In general, only the bottom eight (8) feet of the manhole will be required to be larger than four (4) feet in diameter.

F. Manhole Steps

- 1) Design Engineer must consider the placement of manhole steps relative to future extensions, whether on-site or off-site.

G. Top of Casting Elevation

- 1) Design Engineer shall verify that the lowest elevation to have gravity sanitary sewer service within each home or building is more than one (1) foot above the lowest top of casting elevation of either the first upstream or downstream manhole on the gravity sewer to which the connection is to be made. This design consideration must be incorporated into finished floor elevations *and a minimum F.F.E. label for the lots where the pad elevation does not meet this requirement.* **Manholes with bolted and gasketed castings can not be used as a relief manhole.** If compliance with this requirement can not be maintained, then a Waiver of Responsibility for Minimum Elevation for Gravity Connection must be recorded against the deed of the parcel.
- 2) Elevations must be set to insure drainage away from manholes *and Top of Casting elevations set at two tenths (0.2) feet above finish grade.*
- 3) Elevations must be set eighteen (18) inches above the *current published DNR* 100 year flood elevation of nearby water ways (including, but not limited to, lakes, ponds, streams and emergency spillways or storm water routing). If this requirement can not be met, then water tight bolted and gasketed castings must be installed.

H. Casting Types

- 1) Water tight bolted and gasketed manhole castings must be installed when the top of casting elevation is less than eighteen (18) inches above the *current published DNR* 100 year flood elevation of adjacent water ways (including, but not limited to, lakes, ponds, streams and emergency spillways or storm water routing). Design Engineer must consider the impact of the emergency storm water routing on sanitary sewer facilities.
- 2) Bolted and gasketed castings or other locking type castings must be installed on manholes located within the boundary of day care centers, schools or other facilities where children are present.
- 3) When bolted and gasketed manhole castings are installed, Design Engineer must carefully consider the finished floor elevation of each home or building. **Manholes with bolted and gasketed castings can not be used as a relief manhole.**
- 4) Castings on manholes in Private systems must be lettered “SEWER” or “PRIVATE SEWER”.
- 5) Refer to the Sanitary Manhole detail on HSE’s Gravity Sanitary Sewer Details sheet for further information.

I. Invert Elevation Differences

- 1) *The invert elevation difference shall be 0.10 feet in manholes which the effluent and influent pipes create an angle of one hundred thirty-five (135) degrees to one hundred eighty (180) degrees.*
- 2) *The invert elevation difference shall be 0.20 feet in manholes which the effluent and influent pipes create an angle of ninety (90) degrees to one hundred thirty-five (135) degrees.*
- 3) The invert elevation difference for manholes in which the effluent and influent pipes create an angle of less than ninety (90) degrees will be determined on a case by case basis. This situation will only be allowed where no other alternative is available *and the invert elevation difference shall be a minimum of 0.30 feet.*
- 4) The invert elevation difference in which a smaller sewer joins a larger one is determined as specified in accordance with Section 33.6 (Changes in Pipe Size) of Recommended Standards for Wastewater Facilities “Ten States Standards” (1990 Edition).

J. Cored Holes, Penetrations, etc.

- 1) For cored holes, penetrations and/or other opening through a manhole or other sanitary structure, HSE recommends a separation of greater than eighteen (18) inches between the outer edges of resilient connectors. If a separation of less than eighteen (18) inches exists, then additional reinforcement will be required in the structure or structure diameter shall be enlarged to provide the required

separation.

- 2) All cored holes, penetrations and/or other opening through a manhole or other sanitary structure must have a minimum separation of eight (8) inches from the outer edge of resilient connectors.
- 3) *All cored holes, penetrations and/or other opening into a manhole or other sanitary structure must have a minimum separation of six (6) inches from any joint, as measured from the nearest joint shoulder, to the penetration.*

K. Drop Manholes

- 1) A drop manhole will need to be constructed when the influent invert elevation is greater than three tenths (0.3) of a foot above the effluent invert elevation.
- 2) The drop must be constructed on the exterior of the manhole.
- 3) *Sewers larger than ten (10) inches proposing drop connections will be evaluated on a case-by-case basis.*
- 4) Internal drops will only be allowed if accepted by Engineer in writing. In this case, the internal drop must be constructed as follows:
 - (a) Connections must be cored and sealed as approved by Engineer.
 - (b) The connection must be centered between the joints of the barrel sections with a minimum of eight (8) inches of separation from the cored hole to any joint or seam.
 - (c) All piping within the manhole must be Polyethylene DR11 fusion welded joints.
 - (d) The top of the drop must be a tee fitting with one branch capped. The cap will prevent flow from by-passing the drop.
 - (e) The internal drop must be anchored to the wall of the manhole with stainless steel support bands/rods and stainless steel "Red Head" anchor bolts. The maximum separation between support rods is ten (10) feet.
 - (f) The manhole must be grouted in such a manner that a channel is formed within the bench wall allowing for smooth flow.
- 5) Refer to the Drop Manhole details on HSE's Gravity Sanitary Sewer Details sheet for further information.

L. Stubs

- 1) Generally, HSE does not permit stubs in a manhole unless the final orientation has been established through master planning.
- 2) If a stub is permitted, HSE generally does not allow one greater than one hundred (100) feet without the addition of a manhole. If Engineer determines that an exception should be granted then no buildings or structures shall be connected to that segment of sanitary sewer until a manhole is added.
- 3) Prior to connecting into a stub, Design Engineer must field verify the size and type/class of pipe to insure proper compliance with these Design

Specifications.

- 4) *For testing purposes the minimum length of any stub is five feet. Plugs directly into the boot are not allowed. For a drop manhole stub a minimum twenty (20) foot length of Ductile Iron Pipe must be installed on the drop connection.*
- 5) *In the plan view either the location of the next manhole that a stub is to serve or the angle from the out going-pipe must be shown.*

M. Bench Walls

- 1) If an end run manhole has no stubs **and** will be extended in the future, then no bench wall shall be installed until the extension is constructed.
- 2) If an end run manhole will not be extended in the future, then the bench wall must extend across the entire width of the manhole with a grouted flow transition at the far wall to the top of the bench wall.
- 3) Generally, HSE does not allow lateral connections into a manhole, however, if a connection is permitted, then the bench wall must be formed to receive flow from the lateral.

N. Flow Monitoring Considerations

Possible installation of a fiberglass trapezoidal, Palmer-Bowlus or Parshall flumes or similar device:

- 1) Provide manufacturer and model number.
- 2) Provide a list of the required “options”. For example, stainless steel sonic bracket, staff gauge, etc.
- 3) Contractor will need to supply shop drawings that will be reviewed and approved by Engineer.
- 4) The manhole casting frame must be drilled with a 3/8 inch stainless steel hook to support the flow monitor. The hook must be bolted to the frame with a rubber gasket.
- 5) Must be installed in a “straight through” manhole with a minimum invert elevation difference of 0.30 feet.
- 6) To avoid surcharge problems, the effluent invert of the monitoring manhole must be at an elevation above the top of the interceptor to which the sewer connects.
- 7) Depending on the type of flume, a manhole width greater than four (4) feet may be required.
- 8) To avoid turbulence, all wye connections and non “straight through” manholes must be constructed to maintain the following separations from the manhole with the monitoring device:
 - (a) Upstream – fifteen (15) pipe diameters.
 - (b) Downstream – fifteen (15) pipe diameters.
- 9) To insure the proper operation of the flume or similar device, the influent sewer must be installed at/or near minimum slope as specified in “Ten States

Standards.”

- 10) Supply power and telephone line for telemetry.
- 11) The flume should not be installed until a minimum of eighty (80) EDU's are connected upstream of the monitoring manhole. Also, no bench wall shall be installed and temporary piping must be added as approved by Engineer.
- 12) Refer to HSE's Flow Monitor Meter Pole detail for further information.

O. Sampling Considerations

- 1) All non-residential Subscribers must have an access point for sampling.
- 2) Engineer may require connection of a building's lateral directly to the receiving manhole. Engineer will determine the orientation of the lateral connection within the receiving manhole.

P. Adding Manholes to Existing Sanitary Sewer Facilities

- 1) HSE does not allow “saddle” or “dog house” manholes.
- 2) Generally, HSE does not allow manholes to be added to sanitary sewer facilities beyond those installed during original construction. Therefore, consideration of future connections must be addressed in the design process. If it is determined by Engineer that an exception should be granted then the following considerations will apply:
 - (a) The new manhole will need to be constructed per HSE's Sanitary Manhole detail.
 - (b) Ductile iron fittings must be used outside of the new manhole.
 - (c) Contractor will need to perform low pressure air and deflection tests on the entire segment of existing sewer, both sides of the new manhole, and vacuum test the new manhole while maintaining continuous service.
 - (d) Engineer may require concrete encasement of the disturbed sanitary sewer facilities and/or a “mud slab” under the proposed manhole to prevent settlement.

Q. Clean-outs

- 1) HSE does not generally permit the installation of a clean-out in place of a sanitary sewer manhole, however, if a substitution is permitted it must meet the following criteria:
 - (a) Engineer must approve of the substitution of a clean-out in writing.
 - (b) The clean-out must be added to the upstream end of an end run gravity sanitary sewer not exceeding one hundred (100) feet in length.
 - (c) No more than two (2) laterals can connect into that section of gravity sanitary sewer.
 - (d) The clean-out must be designed per the manhole requirements of these Design Specifications.

- 2) The clean-out must be installed as a Type 2 or Type 3 clean-out. Refer to the Typical Cleanout detail of HSE's Gravity Sanitary Sewer Details sheet for further information.

R. Refer to the Sanitary Manhole, Drop Manhole, Flow Channel, Manhole Cover and Adjusting Ring details of HSE's Gravity Sanitary Sewer Details sheet for further information.

6.09 - Laterals

A. HSE prefers not to install laterals on sewers with an Ultimate Depth of twenty (20) feet or greater *and/or to sewers eighteen (18) inches or larger*. Therefore, Design Engineer shall contact Engineer to discuss alternatives. For example, a parallel shallow sewer, special lateral construction, etc.

B. Generally, HSE does not allow lateral connections to a sewer beyond those installed during original construction. Laterals must connect to the sanitary sewer only at manufactured fittings (except as otherwise permitted by these Design Specifications). No "saddle" connections to the sanitary sewer will be allowed. Therefore, consideration of future connections must be addressed in the design process. If it is determined by Engineer that an exception should be granted then the following considerations will apply:

- 1) By-pass pumping may be required to maintain continual service to all upstream users.
- 2) Disconnect the existing sewer at an existing joint.
- 3) Contractor to maintain existing line and grade for reconstructed sewer.
- 4) Install ductile iron coupling with transition gasket for the wye/existing sewer connection.
- 5) The additional wye and coupling must be concrete encased.
- 6) Contractor will need to perform low pressure air and deflection tests on the entire segment of sewer, both sides of the new wye, while maintaining continuous service. The low pressure air test may require segmentation of the sewer.

C. All laterals must be a minimum of six (6) inches in diameter and sized based on the anticipated flows. For example, a lateral servicing a pool house may need to be larger based on the peak filter backwash flow.

D. Lateral length

- 1) Unless approved by Engineer in writing, no more than one hundred (100) feet of a lateral shall exist within a public right-of-way or beyond the boundary of the lot or parcel for which the lateral is designed to service.
- 2) Unless approved by Engineer in writing, no lateral shall be greater than two hundred (200) feet in length.

E. Slope

- 1) Slope requirements must conform to the latest edition of the State of Indiana (Uniform Plumbing Code), local codes and to these Design Specifications, whichever is more stringent.
- 2) Laterals must be installed at a minimum of 1.00% and where possible, not exceed 6.00%. Engineer, depending on site conditions, may waive the slope requirements.

F. No more than one (1) building or residence will be permitted to connect into a lateral unless the prior written approval of Engineer is obtained. Except for existing homes served by laterals installed with new construction two existing homes may be served by a single lateral.

G. Laterals can not connect directly into a manhole, except as follows:

- 1) Approved by Engineer in writing.
- 2) On deep (greater than twelve (12) feet) or interceptors greater than ten (10) inches in diameter.
- 3) On buildings in which HSE may wish to flow monitor or sample flow characteristics.
- 4) On buildings in which additional access to the Lateral would be helpful. For example, schools.

H. Laterals must connect to the main line sewer at an angle (as measured from the direction of flow) that is greater than ninety (90) degrees.

I. *The tee wyes for a lateral must be located on the sanitary sewer mainline must be designated and installed to obtain a 1:1 ratio away from manhole structures (depth of manhole: distance of tee wye from manhole).*

J. Where possible, wyes and laterals should be located to avoid the following situations:

- 1) Installation on interceptors greater than ten (10) inches.
- 2) Installation on sewers constructed of ductile iron or AWWA C900 pipe.
- 3) Installation on sewers which are concrete encased/capped.
- 4) Installation below pavement or concrete, including streets, driveways, parking lots, etc.
- 5) Installation below storm sewers or water ways.
- 6) Installation below other utilities.
- 7) Installation below mounding, retaining/landscaping/entrance walls and landscaping.
- 8) Installed with less than ten (10) feet of horizontal separation from utilities, streets, storm sewers, water ways, buildings, etc.

- K. Laterals must be extended to the approximate midpoint of the frontage of the lot. Any other location must be approved by Engineer in writing.
- L. Within the subject lot or parcel, laterals must be designed to maintain a minimum separation of ten (10) feet from boundary lines when service is from the front of the lot. A five (5) foot separation from the boundary lines must be maintained when service is from the rear of the lot. Additional separation may be required based upon Ultimate Depth of the lateral and/or soil/groundwater conditions.
- M. When a lateral crosses a parcel other than the property it is intended to service, it must be constructed within a sanitary sewer easement or utility easement. The lateral must maintain a minimum horizontal separation of ten (10) feet measured from the spring line of the pipe to the edge of the easement. Additional separation may be required based upon Ultimate Depth of the lateral and/or soil/groundwater conditions.
- N. During construction of the main line sewer, laterals must terminate within a sanitary sewer or utility easement and be sealed with a manufactured cap/plug made specifically for the purposed of sealing/capping the end of the sanitary sewer to ensure 100% water tightness. *The termination point must be a minimum of five (5) feet from the building line.*
- O. *All laterals must be installed with an insulated #10 copper tracer wire along the top of pipe from the wye to the terminus. The mainline contractor shall install the wire from the wye to the lateral marker at the surface. The lateral contractor shall extend the wire from the terminus to the cleanout adjacent to the building.*
- P. From the wye installed on the sewer main the first length of pipe on all long side laterals must be laid upon undisturbed ground. The first length of pipe for the short side lateral may be laid upon fill made up of #8 stone. *If the sewer is deeper than 25 feet then both long side and short side laterals may not be laid at a slope greater than 45 degrees.*
- Q. Laterals must be located to maintain minimum horizontal separations from utilities, streets, storm sewers, water ways, buildings, etc. as described later in this section of these Design Specifications.
- R. No fittings of greater than forty-five (45) degrees (1/8 bend) can be used.
- S. Separation between wye fittings for opposite side laterals to be one (1) foot minimum for bell to bell. Bell to spigot may be adjacent only when approved by engineer. For same side laterals a minimum five (5) foot separation must be used. Common trenches for more than one lateral are not allowed, unless the minimum horizontal spacing between laterals can be maintained.

- T. All PVC fittings must be ASTM D-3034 SDR-26 heavy wall minimum. Bell to spigot fittings may only be approved by the Engineer.
- U. Laterals must have a wye clean-out located within three (3) feet of the building's exterior wall and subsequent clean-outs must be installed at a maximum interval of one hundred (100) feet. Therefore no section of lateral between the building and main line sewer shall exceed one hundred (100) feet without the installation of a clean-out.
- V. From the building to the main line sewer, it is recommended that a clean-out be installed after every three (3) fittings of 22.5 degrees or more, but in no case exceeding five (5) fittings between clean-outs.
- W. When service is from the rear a clean-out must be installed either on the side or front of the building so that a clean-out is always accessible, not fenced in.
- X. Type 1 clean-outs must be installed in grass or landscape areas located within three (3) feet of the buildings exterior wall. All other installations must be Type 2 or Type 3.
- Y. All clean-outs must be the same diameter as the horizontal lateral into which the clean-out is connected being a minimum of six (6) inches.
- Z. The top of clean-out elevation must be designed in the same fashion specified for Sanitary Sewer Manholes in section 6.08 G (2&3) of these Design Specifications. The Top of Casting (TC) for both Type 2 and Type 3 clean-outs must be shown on the Development Plan and Plot Plans if applicable.
- AA. Refer to HSE's "Design and Construction of Laterals" for further information.
- BB. Refer to the Service Lateral and Typical Cleanout details of HSE's Gravity Sanitary Sewer Details sheet for further information.

6.10 - Force Mains and Common Force Mains

- A. Air/Vacuum Relief Valves
 - 1) Air/vacuum relief valves must be located at all high points along the force main.
 - 2) Intermediate air/vacuum relief valves must be located at a maximum interval of 1/4 mile (1,320 feet).
 - 3) Engineer will make the determination as to the location and type of air/vacuum relief valves. Early coordination is recommended to eliminate delays during design.
 - 4) Design Engineer must consider both initial and ultimate flow ranges in sizing

air/vacuum relief valves. Design Engineer must submit calculations for review and approval.

- 5) The top of casting elevation of air/vacuum relief manholes must be designed in the same fashion as specified for Sanitary Sewer Manholes in this section of these Design Specifications.
- 6) Access to air/vacuum relief manholes must be designed in the same fashion as specified for Sanitary Sewer Manholes in this section of these Design Specifications.
- 7) Refer to the Air/Vacuum Relief Manhole detail of HSE's Lift Station & Force Main Details sheet for further information.

B. Clean-outs

- 1) Clean-outs must be located at all low points along force mains with a diameter of twelve (12) inches or greater and as directed by Engineer.
- 2) Engineer will make the determination as to the location of clean-outs. Early coordination is recommended to eliminate delays during design.
- 3) The top of casting elevation of clean-out manholes must be designed in the same fashion as specified for Sanitary Sewer Manholes in this section of these Design Specifications.
- 4) Access to clean-out manholes must be designed in the same fashion as specified for Sanitary Sewer Manholes in this section of these Design Specifications.
- 5) Refer to the Clean-Out Manhole detail of HSE's Lift Station & Force Main Details sheet for further information.

C. Velocities in force mains of less than three (3) feet per second will only be accepted if the lift station or pumps are planned to be upgraded in the future.

D. No fittings of greater than forty-five (45) degrees (1/8 bend) can be used, except within the valve vault.

E. All fittings shall be ductile iron with restrained joints. Restraining bolts and rods shall be stainless steel.

F. Thrust blocks must be installed as detailed on the Force Main Thrust Blocking detail of HSE's Lift Station & Force Main Details sheet.

G. In accordance with "Recommended Standards for Wastewater Facilities" 2004 Edition Section 49.5 there shall be at least a 10 foot horizontal separation between water mains and sewer force mains except for crossings. Crossings shall be at 90 deg or nearly so with an 18 inch separation between mains.

H. Flow Monitoring Considerations

Possible installation of a transit time or Mag meter with American Sigma model 970 Data Logger mounted to the control panel or similar device:

- 1) Provide manufacturer and model number.
- 2) Provide a list of the required “options”.
- 3) Contractor will need to supply shop drawings that will be reviewed and approved by Engineer.
- 4) Must be installed in a “straight through” manhole.
- 5) A manhole width of five (5) feet is required.
- 6) To avoid turbulence, all fittings must be constructed to maintain the following separations from the manhole with the monitoring device:
 - (a) Upstream – fifteen (15) pipe diameters
 - (b) Downstream – fifteen (15) pipe diameters
- 7) In the area of the flow monitor, the force main must be designed to remain full at all times.

I. Force Main Discharge

- 1) Discharge to gravity sewers
 - (a) Discharges directly to gravity sewer lines via an existing *pressure rated* wye are the preferred method for force mains that are smaller than the gravity sewer to which the connection will be made.
 - (b) When connecting to a wye, a plug valve must be installed to allow for testing of the force main. The valve box must be lettered “Sewer”.
 - (c) If a wye does not exist, contact Engineer to discuss adding a *pressure rated* wye.
- 2) Discharges to manholes
 - (a) It is recommended that the discharge be one hundred eighty (180) degrees from the effluent sewer. If the discharge can not be one hundred eighty (180) degrees from the effluent sewer, then it must be constructed two (2) inches above the top of the effluent pipe, but not greater than two (2) feet above the invert of the effluent pipe.
 - (b) Channels must be provided in the manhole for all force main discharges.
 - (c) Channels must be the size of the effluent sewer.
 - (d) Channels must be straight (not with a radius) to the greatest extent possible.
 - (e) Channels must be designed with the same elevation difference as specified for Sanitary Sewer Manholes in this section of these Design Specifications.
- 3) If a force main connects to an existing gravity sewer, then Design Engineer shall contact Engineer to determine the upstream and downstream manholes

that will be coated with 1/4" Neopoxy NPR-5300 as manufactured by Neopoxy International or Spectrashield as manufactured by CCI Spectrum Inc. or other Engineer approved method. This coating is to be applied to all structures, both upstream and downstream, within five hundred (500) feet or greater, if determined by the Engineer, of the point of connection.

- 4) If a force main connects to a proposed gravity sewer, then Design Engineer shall contact Engineer to determine the specification and extent of upstream and downstream manholes that will be installed as one piece fiberglass reinforced polyester manholes.
- 5) A bolted and gasketed casting must be installed on each manhole within two hundred (200) feet of a force main discharge.
- 6) Refer to the Force Main to Gravity Sewer detail of HSE's Lift Station & Force Main Details sheet for further information.

J. Odor Control

- 1) Generally, odor control facilities will be required in lift stations and manholes receiving discharge from a force main with a substantial length or lift station with a substantial cycle time. Engineer will make the determination as to the need for odor control. Early coordination is recommended to eliminate delays during design.
- 2) Earth Filters
 - (a) Required for small (*two (2)*) inch or *larger*) force main connections or air release structures.
 - (b) No hardscape surfaces can be constructed over the earth filter bed.
 - (c) The earth filter must be contained within an exclusive sanitary sewer easement. Filter layout must be shown in plan view.
 - (d) Refer to the Odor Control Earth Filter detail of HSE's Lift Station & Force Main Details sheet for further information.
- 3) Sodium Hypochlorite Injection System
 - (a) A building will need to be constructed for the sodium hypochlorite injection system within ten (10) feet of the valve vault.
 - (b) HSE's Sodium Hypochlorite Odor Control Facilities detail must be included with the set of Construction Plans. Contact Engineer for a copy of this detail.
- 4) Power ventilated scrubber using media as manufactured by Sulfa Treat (Sulfa Treat 410HP) and an activated carbon bed. Scrubber shall be 316L SS with fiberglass grating supports. Fan shall be as manufactured by New York Blower and shall be FRP with stainless steel impeller.
 - (a) Media bed sizing shall be as determined by Engineer.
 - (b) Air flow rate shall be as determined by Engineer.

K. No storm sewer or utility crossings will be permitted within eighteen (18) inches above or six

(6) inches below force mains. Engineer will not permit the installation of concrete cradles on force mains.

L. *Contractor must install insulated #10 copper tracer wire with all force mains. In addition, "marker balls" must be installed directly above the force main no deeper than three (3) feet below finish grade every two hundred fifty (250) feet on straight runs and above all fittings where the direction of the pipe changes.*

M. *All operating nuts on all valves must be extended to within one (1) to two (2) feet of finish grade.*

N. In regards to common force mains:

- 1) Service valve boxes shall not be installed until final grading of the lot or parcel and connection of the home or building.
- 2) Isolation valve boxes must be installed at the time of initial construction; however, castings may need to be adjusted after final grading.
- 3) It is highly recommended that pumps be external to the building. Sewage backups into the wet well/building may occur due to failure of the pump, check valve or appurtenances, thus allowing sewage to flow into the wet well/building. Any backup into the wet well/building will be the sole responsibility of the property owner. HSE is not liable or responsible in any way for damages due to sewage backups in wet wells/buildings served by grinder/ejector pumps.
- 4) The top of the wet well/sump must be:
 - (a) *Eighteen (18) inches above the current DNR 100 year flood elevation of nearby waterways.*
 - (b) And it is highly recommended to be one (1) foot below the lowest elevation to have sanitary service in the home or building.

6.11 - Lift Stations, Grinder Pumps and Effluent Pumps

A. Required calculations, for proposed and future conditions, include:

- 1) Cycle time at 1/2 pump rate (minimum cycle time),
- 2) Cycle time at average flow,
- 3) Cycle time at low flow,
- 4) Total dynamic head ("TDH"), including:
 - (a) Static head,
 - (b) Pipe and fitting head losses within lift station, and
 - (c) Pipe head losses in the force main.
- 5) The TDH curve plotted with the proposed pump curve, and
- 6) Buoyancy.

- B. Calculations that may be required, at Engineer's discretion, include:
- 1) Static regain,
 - 2) Water hammer, and
 - 3) Common force main head conditions.
 - 4) Maximum and average residence time of sewage in the force main.
- C. Calculations will be required for the initial and future operating conditions and may be required for intermediate conditions.
- D. Calculations must be signed and sealed by an appropriately registered Indiana professional.
- E. All lift stations must be of the submersible type with 460 volt, three (3) phase power.
- F. Pumps must have motors sized to be non-overloading throughout the entire range (from shut-off head to the end of the curve) of the pump curve.
- G. All I&A Tanks, grinder pumps and effluent pumps must have an electrical disconnect switch mounted adjacent to the wet well.
- H. Impellers must be provided for both the initial and future conditions.
- I. In accordance with "Recommended Standards for Wastewater Facilities" 2004 Edition section 42.25 materials selected for use in and around the lift station shall be selected that are appropriate under conditions of exposure to hydrogen sulfide and other corrosive gases, greases, oils, and other constituents frequently present in wastewater. This is particularly important in the selection of metals and paints. Contact between dissimilar metals should be avoided or other provisions made to minimize galvanic action.
- J. Consideration must be given to the size of guide rails, base elbows and discharge piping such that they are capable of handling the ultimate pumps anticipated for the lift station.
- K. Consideration must be given to the control panel such that it is of adequate size to handle starters and wiring for the ultimate pumps anticipated in the lift station.
- L. Design Engineer must consider the following while sizing the wet well:
- 1) Ultimate size/horse power of pumps.
 - 2) Manufacturer's suggested distance for anti-vortex plates isolating each pump.
- M. Design Engineer must consider the following while sizing the valve vault:
- 1) A minimum separation of three (3) feet must be maintained between outside piping and the wall of the valve vault.
 - 2) A minimum separation of two (2) feet must be maintained between the ladder

(each side) and the wall of the valve vault.

- N. *The top of wet well and valve vault elevations must be set eighteen (18) inches above the current DNR 100 year flood elevation of nearby water ways (including, but not limited to, lakes, ponds, streams and emergency spillways or storm water routing).*
- O. Grading of the lift station site must be designed to insure drainage away from the wet well and valve vault. A diversion swale around the lift station may be required.
- P. An asphalt drive will be required from the nearest public street to the wet well. The asphalt drive must be designed in the same fashion as specified for Sanitary Sewer Manholes in this section of these Design Specifications. *Contact Engineer for the required turning radius templates.*
- Q. The lift station site must be situated such that vehicles can access the wet well for pump removal without driving over the valve vault or manholes of the influent sewers.
- R. A level (all directions) fourteen (14) foot by twenty (20) foot generator parking area must be provided at each lift station site.
- S. The control panels and generator receptacle must be located within ten (10) feet of the lift station drive so that a portable generator can be readily connected to the generator receptacle.
- T. A fence must be installed around the wet well and valve vault. The following items must be considered while determining the area enclosed by the fence:
 - 1) Adequate work area for all maintenance workers and equipment.
 - 2) Adequate work area to read all meters and open all doors.
 - 3) Adequate storage space for the emergency generator.
 - 4) At a minimum, the section of fence with the gate must be twenty (20) feet wide.
 - 5) The distance from the open face of the gate to right-of-ways must be a minimum of thirty-five (35) feet.
- U. The buoyancy of lift stations must be considered. When designing the concrete collar, the minimum width to height ratio should be 1.5:1 with a minimum height of twelve (12) inches. Design Engineer may need to increase the height dimension based on anticipated shear forces.
- V. Refer to HSE's Duplex/Initial Triplex/Triplex Lift Station Plan, Lift Station & Force Main Details, Initial Triplex/Triplex Lift Station Electrical Diagram and Lift Station & Force Main Specifications sheets for further information.

6.12 - Separation from Buildings and Structures

- A. All buildings and structures must be constructed at a minimum horizontal distance from sanitary sewer facilities. Based on the Ultimate Depth (from invert to grade) of the sanitary sewer facilities, the minimum horizontal separation (as measured horizontally from the spring line of the pipe to the edge of the building foundation) is as follows:

<u>Depth of Sewer</u>	-	<u>Separation</u>
Up to 15 feet	-	10 feet
15 to 20 feet	-	12.5 feet
20 to 25 feet	-	15 feet
25 to 35 feet	-	20 feet
Over 35 feet	-	Case by case basis

Additional separation may be required based upon soil/groundwater conditions.

- B. No sanitary sewer facilities should be designed to cross below any permanent or temporary buildings or structures.
- C. Based on the Ultimate Depth (from invert to grade) of the sanitary sewer facilities, all bridges must be designed to maintain a minimum horizontal separation (as measured horizontally from the spring line of the pipe to the edge of the wing wall foundation) as follows:

<u>Depth of Sewer</u>	-	<u>Separation</u>
Up to 15 feet	-	15 feet
15 to 20 feet	-	17.5 feet
20 to 25 feet	-	20 feet
25 – 35 feet	-	25 feet
Over 35 feet	-	Case by case basis

6.13 - Separation from Water Supplies

- A. Sewers must be laid at least ten (10) feet horizontally (as measured from the spring lines) from any existing or proposed water main. The distance is to be measured from the spring line of the pipes. Should specific conditions prevent this separation, the Design Engineer must notify the Engineer for specific instructions.
- B. Whenever the sewer, *either main or lateral*, crosses a water main, it should be laid at least eighteen (18) inches below the *water* main.
- C. When the above conditions cannot be maintained, the sewer must be constructed of waterworks grade ductile iron pipe with mechanical joints or PVC ASTM D-2241 SDR 21 or

AWWA C-900/C-905 DR 18 pressure sewer pipe with compression fittings. The joints must be located equidistant in both directions from the water main. The sewer must be the type of pipe described above for a minimum of twenty (20) feet beyond the cross point. Special structural support for the water main and sewer may be required.

- D. All crossings are to be at an angle of 45 degrees or greater.
- E. *All water main fittings and thrust blocks must be separated from the sanitary sewer by one half (1/2) the distance specified in Section 3.03A, Minimum Easement Width, for the sanitary sewer in question.*
- F. Separation from water wells shall be in accordance with ISBH BULLETIN S.E. 13 current addition and shall meet the following minimum distances.
- 1) *Public Water System Drinking Water Wells*
The minimum separation distance between the following sanitary sewer facilities and public water system drinking water wells shall be as follows:
 - (a) *Sanitary Sewers - Two Hundred (200) feet*
Sanitary Sewers may be located within two hundred (200) feet, but under no circumstances less than fifty (50) feet, from a public drinking water well if pressure rated PVC or DIP, as specified for force mains, is used.
 - (b) *Manholes - Two Hundred (200) feet*
 - (c) *Lift Stations - Two Hundred (200) feet*
 - 2) *Commercial Water System Drinking Water Wells*
The minimum separation distance between the following sanitary sewer facilities and commercial water system drinking water wells shall be as follows:
 - (a) *Sanitary Sewers - One hundred (100) feet*
Sanitary sewers may be located within one hundred (100) feet, but under no circumstances less than forty (40) feet, from a commercial drinking water well if pressure rated PVC or DIP, as specified for force mains, is used.
 - (b) *Manholes - One hundred (100) feet*
 - (c) *Lift Stations - One hundred (100) feet*
 - 3) *Private Water Supply Wells*
The minimum separation distance between the following sanitary sewer facilities and private water supply wells shall be as follows:
 - (a) *Sanitary Sewers - Fifty (50) feet*
Sanitary sewers may be located within fifty (50) feet, but under no circumstances less than thirty five (35) feet, from a private water

supply well if pressure rated PVC or DIP, as specified for Force main, is used.

(b) Manholes - Fifty (50) feet

(c) Lift Stations - Fifty (50) feet

- G. Refer to the Well/ Water Supply & Sewer Crossing detail of HSE's Gravity Sanitary Sewer Details sheet for further information.
- H. Sewer/water supply separations and pipe classifications must conform with 327 IAC 3-6-9.
- I. The abandonment of all wells must conform to the standards outlined in the latest amendment of Title 310 IAC 16.

6.14 - Utility Separation and Utility Crossings

- A. All utilities should be designed to cross sanitary sewer facilities as close to ninety (90) degrees as possible.
- B. Based on the Ultimate Depth (from invert to grade) of the sanitary sewer facilities, all utilities must be designed to maintain a minimum horizontal separation (as measured horizontally from the spring lines) as follows:

<u>Depth of Sewer</u>	-	<u>Separation</u>
Up to 15 feet	-	10 feet
15 to 20 feet	-	12.5 feet
20 to 25 feet	-	15 feet
25 to 35 feet	-	20 feet
Over 35 feet	-	Case by case basis

- C. Design Engineer should carefully review vertical conflicts of the sanitary sewer facilities (including laterals) with all utilities.
- D. *Lateral Tee wyes/Wyes are to be located so that no storm sewer, water main or gas main (four (4) inch or larger) crossing will be located over the fitting. The minimum separation as measured horizontally between the fitting and the crossing shall be equal to the depth of cover between the fitting and the crossing utility.*
- E. Except for force mains, a concrete cradle must be incorporated into the design when the separation distance (as measured from outside-of-pipe to outside-of-pipe) between the sanitary sewer facilities and any other utility is eighteen (18) inches or less. A minimum clear distance of three (3) inches must be provided to maintain structural integrity of the concrete. Refer to the Concrete Cradle detail of HSE's Gravity Sanitary Sewer Details sheet

for further information.

- F. When crossing a gas/petroleum pipeline maintain a minimum vertical separation of two (2) feet between outside of pipes.
- G. It is the responsibility of the Owner or their authorized representative to coordinate with and get approvals from various utilities, including governmental agencies that have jurisdiction locally over areas where work is being performed for all proposed work. Further, it is the responsibility of the Owner to get authorization to encroach upon any other utility easement(s) and secure such recorded encroachment prior to construction.

6.15 - Street Separation and Street Crossings

- A. All sanitary sewer facilities should be designed to cross streets or hardscape surfaces as close to ninety (90) degrees as possible.
- B. Based on the Ultimate Depth, the minimum horizontal separations must be the same as those indicated for Utility Separation and Utility Crossings in this section of these Design Specifications.

6.16 - Storm Sewers, Field Tiles and Water Ways

- A. Where possible, storm sewers should be designed to cross sanitary sewer facilities as close to ninety (90) degrees as possible.
- B. Based on the Ultimate Depth, the minimum horizontal separations must be the same as those indicated for Utility Separation and Utility Crossings in this section of these Design Specifications.
- C. A minimum of twenty (20) feet of horizontal separation (as measured horizontally from the sewer spring line) must be maintained between gravity sewers and the top of bank of all water ways, bodies of water and dry detention areas.
- D. At minimum cover (4.5 feet), a minimum of ten (10) feet of horizontal separation must be maintained between force mains and the top of bank of all water ways, bodies of water and dry detention areas. The minimum separation distance will increase depending on the Ultimate Depth of the force main.
- E. When crossing a water way, the sanitary sewer facilities should be designed to cross as close to ninety (90) degrees as possible. HSE will not permit the crossing of bodies of water including, lakes and retention/detention ponds or dry detention areas.

- F. When crossing a water way, sanitary sewer facilities must be concrete encased to ten (10) feet beyond the top of banks.
- G. The following items are recommended by the Hamilton County Surveyor's office when sanitary sewer facilities are constructed within a legal drain:
 - 1) A minimum cover of five (5) feet must be provided from the bed of the water way to the top of the concrete encasement.
 - 2) A minimum horizontal separation of thirty (30) feet must be maintained between the top of bank and the center of sanitary sewer manholes and clean-outs.
 - 3) *Contractor must verify flow line elevation of legal drain prior to construction and notify Engineer if variance exists.*
- H. If less than five (5) feet of cover is provided from the bed of the water way to the top of the concrete encasement, then the sanitary sewer facilities must be installed as ductile iron pipe from ten (10) feet beyond the top of banks. HSE may also require a maintenance agreement and fee for future relocation.
- I. Design Engineer should carefully review vertical conflicts of the sanitary sewer facilities (including laterals) with all storm sewers.

6.17 - Landscaping, Retaining Walls, Lighting, Fencing, Signs, etc.

- A. Owner *may* place or permit to be placed any trees or other deep rooted landscaping *with separation as specified in the current (at the time of planting) HSE Approved Tree List. For trees not listed in the HSE Approved Tree List a minimum separation of ten (10) foot horizontal distance from Laterals or any other sanitary sewer facilities (as measured from the drip line of the mature tree to the center of sanitary sewer facilities) must be maintained.* Any trees or landscaping placed within easements or right-of-ways are at risk of being damaged or removed by HSE without the obligation of replacement.
- B. Trees or shrubs can not be planted directly over building laterals.
- C. Based on the Ultimate Depth, mounding installed parallel to a sewer must be designed to maintain the same minimum horizontal separations as those indicated for Utility Separation and Utility Crossings in this section of these Design Specifications.
- D. Mounding, even when crossing at ninety (90) degrees, must not be constructed directly over sanitary sewer facilities.
- E. Lighting, fencing, signs, retaining/landscaping/entrance walls, irrigation lines, walking paths that are not within the Right of Way or within existing easements, etc. must be

designed to maintain a minimum horizontal separation of ten (10) feet (possibly further depending on Ultimate Depth) as measured from the nearest edges to the center of the sanitary sewer facilities.

- F. HSE does not generally permit the installation of sanitary sewer facilities below retaining/landscaping/entrance walls, however, if a crossing is permitted it must meet the following criteria:
- 1) Engineer must approve of the crossing in writing.
 - 2) The sanitary sewer facilities should be designed to cross as close to ninety (90) degrees as possible.
 - 3) Sanitary sewer facilities must be designed as either ductile iron pipe or PVC pipe with a casing a minimum of ten (10) feet beyond each side of the wall. Engineer will determine the appropriate procedure.
 - 4) If a casing is installed refer to the Typical Boring detail (for railroads) of HSE's Gravity Sanitary Sewer Details sheet for further information.
- G. HSE may perform field inspections after final build-out to verify compliance with the above mentioned requirements. If a violation exists then the Subscriber will be asked to immediately remedy the situation or record a Waiver of Responsibility. Therefore, Subscriber and Design Engineer should thoroughly review the impact of landscaping items to the Project.

6.18 - Bores

- A. Street bores must extend beyond the street surface at a 1:1 ratio relative to depth of the sanitary sewer facilities and extend beyond the existing/proposed right-of-way.
- B. Railroad bores must extend beyond the center of the tracks at a 1:1.5 ratio relative to depth of the sanitary sewer facilities and extend beyond railroad right-of-way.
- C. Refer to the Typical Boring detail of HSE's Gravity Sanitary Sewer Details sheet for further information.
- D. Engineer will evaluate the use of directional bores based upon required minimum slope of 1% for gravity sewers, results of soil borings (ground water elevation, location of rock, etc.) and location of other utilities. See Directional Bore Construction Specifications for additional guidance.

6.19 - Future Land Use

When sanitary sewer facilities cross undeveloped parcels Design Engineer should consider the future land use of the parcel pertaining to the following:

- A. Installation of all weather access drives for maintenance access to the sanitary sewer facilities.
- B. Installation of a stronger grade of pipe for areas that may receive fill at a later date.
- C. Installation of granular backfill over the sanitary sewer facilities in areas that may receive vehicular traffic. For example, roads, drives, parking areas, etc.
- D. Location of manholes so that pavement or concrete, including driveways and sidewalks, will not be constructed on or within one (1) foot horizontal distance of manhole castings.
- E. Correct location of manholes and wyes to be installed during construction related to future connections.
- F. Other factors impacting the proper design and construction of sanitary sewer facilities.

6.20 - Compliance

- A. Engineer will make final determinations as to the ability to reasonably comply with these Design Specifications.
- B. These Design Specifications are intended to define the design requirements of sanitary sewer facilities which are constructed and operated under typical conditions in HSE's service area. Depending on field conditions and the composition and characteristics of the sanitary sewer flow, different or unusual conditions may occur which cannot be anticipated in a document of this nature. Consequently, Engineer may impose additional or special design requirements under such circumstances.

SECTION 7 - CONSTRUCTION PLAN DOCUMENTATION

7.01 - Permits

Prior to approval of the construction drawings, HSE will request copies of the approved permit or written approval from any government agency or public entity impacted by the construction of a Project. This includes permits and approvals from the following:

- A. Indiana Department of Environmental Management.
- B. Indiana Department of Transportation.
- C. Corp of Engineers.

- D. Department of Natural Resources.
- E. Hamilton County Surveyor.
- F. Hamilton County Highway.
- G. Town of Fishers.
- H. Fishers Port Authority.
- I. City of Noblesville.
- J. Any other government agency or public entity.

7.02 - General

- A. Construction Plans and associated documentation must be reviewed and approved by Engineer, as HSE's representative, for compliance with these Design Specifications and HSE's Master Plan and other standards, specifications and details.
- B. The minimum amount of review time per submittal, required by Engineer, is fourteen (14) days. Additional review time will be required for complex Projects, including off-site sewers, large scale architectural projects, connection of existing building, etc. When submitting to Engineer, Subscriber and Design Engineer should carefully consider the complexity of the Project and the amount of review time required to avoid delays in the issuance of approvals and permits.
- C. When submitting to Engineer include two (2) complete sets of Construction Plans with all supporting documentation including, architectural plans, bridge plans, etc. Design Engineer shall deliver one (1) copy each to HSE and Engineer at their respective business addresses.
- D. Every sheet of the Construction Plans must include the following:
 - 1) Be prepared on AutoCAD Release *14* (or higher) or capable of being converted to a DXF file. If this presents a problem, then contact Engineer to discuss possible alternatives.
 - 2) Most current name of the Project, including section/phase number.
 - 3) Certification indicating the following:
 - (a) Stamped by an appropriately registered Indiana professional.
 - (b) Signed.
 - (c) Dated.
 - 4) All drawings must be plotted with a horizontal scale of 1" = 10', 20', 30', 40',

50' or 60' and a vertical scale of 1" = 1', 2', 3', 4', 5' or 6'. The scale of the drawing shall present the information clearly and allow Engineer the ability to scale dimensions. If Engineer has difficulty scaling dimensions or reading the data, then Design Engineer may be requested to re-plot drawings at a different scale.

- 5) All drawings must be true to scale and submitted on 24" x 36" sheets.
- 6) The scale and a north arrow must be indicated.
- 7) All dimensions, distances, elevations, etc. shall be displayed in feet, except pipe diameters which shall be displayed in inches.
- 8) HSE must be listed as the local sanitary sewer utility. Address - 11901 Lakeside Drive, Fishers, Indiana 46038. Telephone number - (317) 577-2300.

7.03 - Primary Plats

Primary Plats must include the following:

- A. A label stating "Primary Plat."
- B. Proposed secondary plat information, including the following:
 - 1) Easements.
 - 2) Right-of-ways.
 - 3) **Entire** project boundary.
 - 4) Lot lines.
 - 5) Sub-section or phase lines.
 - 6) Building lines.
 - 7) Street names.
 - 8) Lot numbers.
 - 9) Block/common area designations
- C. Graphical representation of all proposed off-site easements.
- D. Location of all proposed and existing sanitary sewer facilities, including the following:
 - 1) Gravity sewers and manholes.
 - 2) Lift stations (wet well and valve vault) and grinder/effluent pumps.
 - 3) I&A tanks.
 - 4) Force mains, force main fittings, isolation/service valves and air/vacuum relief manholes.
 - 5) Force main or lateral (Type 1, 2, or 3) clean-outs.
 - 6) End of stubs (no matter the length of the stub).
 - 7) Septic fields.
- E. Indicate all pavement within the boundary of the Project and off-site pavement to be constructed to service the Project.

- F. Storm sewers and the top of bank of all water ways (including, but not limited to, lakes, ponds, streams and emergency spillways).
- G. Legal drain and flood way limits.
- H. Topography.

7.04 - Secondary Plats

- A. A secondary plat must be provided with each set of original/revised Construction Plans submitted.
- B. Graphical representation of all recorded on-site easements and Certificates of Correction with their corresponding instrument numbers.
- C. All sanitary sewer facilities that will be constructed within a block, common area, etc. must be contained within land to be platted as a sanitary sewer easement or utility easement.
- D. Refer to the Easements and Deeds section of these Design Specifications for further information.
- E. All variable easements must be geometrically defined so that their size and or location is defined and not left open to interpretation.

7.05 - Title sheet

The Title Sheet must include the following:

- A. A label stating “Construction Drawings”.
- B. A site map which indicates all on-site and off-site sanitary sewers and manholes, manhole numbers, lot numbers and lot lines.

7.06 - Site Development Plan

The Site Development Plan must include the following:

- A. The Site Development Plan must be plotted at one of the following scales: 1” = 10’, 20’, 30’, 40’, 50’ or 60’.
- B. The current secondary plat information, including the following:
 - 1) Easements.
 - 2) Right-of-ways.

- 3) **Entire** boundary indicated with a bold line.
 - 4) Lot lines.
 - 5) Label sub-section or phase lines and indicate with a bold line.
 - 6) Building lines.
 - 7) Street names.
 - 8) Lot *or building* numbers.
 - 9) Block/common area designations.
- C. If the property is not going to be platted, indicate the entire boundary of the property with all easements, right-of-ways, streets, street names, building numbers and phase lines.
- D. Graphical representation of all off-site platted easements, right-of-ways, lot lines, building lines, etc. encompassing sanitary sewer facilities constructed with the Project.
- E. Graphical representation of the entire boundary for all recorded off-site and on-site easements (affecting the sanitary sewer facilities or crossing within the boundary of the Project), Certificates of Correction (affecting sanitary sewer facilities or otherwise) and deeds (for lift station parcels) with their corresponding instrument numbers.
- 1) Provide copies of recorded easements to Engineer.
 - 2) Indicate the name of the grantee(s).
 - 3) It may be necessary to add leaders to distinguish the boundaries.
- F. Graphical representation of all proposed off-site easements or right-of-ways. Upon being recorded, forward recorded copies to Engineer.
- G. Location of all proposed or existing (indicate as a “screened” line type) sanitary sewer facilities, including the following:
- 1) Gravity sewers and manholes.
 - 2) Wyes, laterals and lateral fittings.
 - 3) Lift stations (wet well and valve vault) and grinder/effluent pumps.
 - 4) I&A tanks.
 - 5) Force mains, force main fittings, isolation/service valves and air/vacuum relief manholes.
 - 6) Force main or lateral (Type 1, 2 or 3) clean-outs.
 - 7) End of stubs (no matter the length of the stub).
 - 8) Special structures (including, grease traps, grit traps, oil/water separators, neutralization tanks, etc.).
 - 9) Septic fields.
- H. Clearly label all structure numbers, however, it is not necessary to provide the proposed manhole and pipe information.
- I. Location of all proposed or existing utilities.

- J. Existing water, gas or oil wells and/or septic fields within two hundred (200) feet of sanitary sewer facilities.
- K. Proposed elevations:
- 1) Pad elevations.
 - 2) Minimum finished floor elevations must be specified if pad elevations do not comply with the required vertical separation from top of casting elevations as described in Sanitary Sewer Manholes under the Design Requirements section of these Design Specifications.
 - 3) Lowest elevation of gravity sanitary sewer service if other than the finished floor elevation.
 - 4) Lot grades.
 - 5) Street grades.
- L. Buildings:
- 1) Existing buildings (even if they will be demolished) such as homes, barns, etc.
 - 2) Proposed buildings (except homes in a subdivision) such as apartments, guard houses, club houses, maintenance barns, etc.
- M. Indicate all pavement and/or access drives within the boundary of the Project and off-site pavement to be constructed to service the Project.
- N. Indicate storm sewers and their structure numbers.
- O. Indicate the top of bank and 100 year flood/normal pool elevations of all nearby water ways (including, but not limited to, lakes, ponds, streams and emergency spillways and storm water routing). The 100 year flood/normal pool elevations must be on the same vertical datum as the Construction Plans; therefore, conversions from NGVD 1929 to NAVD 1988 will be required.
- P. Indicate legal drain and flood way limits.
- Q. Indicate emergency storm water routing.
- R. Indicate topography.
- S. All items required on Landscaping and other related plans if a separate Landscaping Plan will not be submitted with the construction set. The requirements are described in Landscaping, Site Lighting and Other Related Plans later in this section of these Design Specifications.
- T. Miscellaneous

- 1) If a sanitary sewer manhole is proposed to be removed during construction, then indicate a note near the appropriate manhole which states, “MH # (provide manhole number) to be removed.”
- 2) If existing structures do not appear on a sanitary sewer plan and profile sheet, and the top of casting elevations need to be adjusted, then provide the existing and proposed top of casting elevations. Also, add a note which states, “Contractor to vacuum test MH’s # (provide manhole number) after top of castings are adjusted. Until final build out, a minimum of one (1) 4” adjusting ring must be installed on each manhole.”
- 3) If manholes are to be installed with calcium aluminate, then indicate a note which states, “Contractor shall coat entire interior of MH #’s (provide manhole numbers) with 1/2” calcium aluminate Aluminaliner, PF coating, as manufactured by Quadex.”
- 4) If existing buildings or structures are on-site and will be serviced by gravity sanitary sewer service, then provide the elevation of the finished floor and the lowest point to have gravity sanitary sewer service (if other than the finished floor elevation).
- 5) If a lateral was provided to an existing lot or building beyond the platted boundary, then that address must also be provided.
- 6) If laterals were previously constructed with another Project, then the as-built wye station and lateral length must be indicated on each individual lot.
- 7) If a lateral is to be abandoned, then indicate a note at the end of the lateral that states, “This lateral to be abandoned in place.” Note: Engineer may require a Type 2 or Type 3 clean-out to be installed at the end of a lateral that will be abandoned.
- 8) If a Type 2 or Type 3 clean-out is to be installed on a lateral, then the clean-out must be labeled (as a Type 2 or Type 3 clean-out) and the top of casting elevation must be provided.
- 9) If a lot or property is proposed to be serviced by a grinder/ejector pump or I&A Tank, then indicate a note on each individual lot which states, “(provide lot number or building name) is proposed to be serviced by a grinder/ejector pump or I&A Tank. An electrical disconnect switch mounted adjacent to the wet well must be installed.”
- 10) If a special structure (including grease traps, grit traps, oil/water separators, neutralization tanks, etc.) is to be installed, then the structure must be labeled and the top of casting elevation must be provided.
- 11) If access drives are proposed for maintenance purposes, then the drives must be labeled and appear in its design location.
- 12) If a well will be abandoned, then indicate a note pointing to the well which states, “Contractor shall abandon well in conformance to the standards outlined in the latest amendment of Title 310 IAC 16.”
- 13) A note is to be placed on the site development plan stating that contractor

shall stamp the letter “S” in the curb perpendicular to the lateral marker.

- 14) If a septic tank or field is to be abandoned then add a note pointing to the tank or field which states “Contractor shall abandon septic tank or septic field in accordance to Hamilton County Health Standards.”

7.07 - Sanitary Sewer Plan and Profiles (Gravity and Force Main)

A. General

- 1) Plan and Profile sheets are required for all main line gravity sewers (eight (8) inches or greater) and force main systems. The sanitary sewer or force main must be depicted on sheets utilized specifically for that purpose. The profiles of storm sewers, streets, etc. must not appear on the Plan and Profile sheets.
- 2) The plan view must include the following:
 - (a) Sanitary sewer structure numbers.
 - (b) Sanitary sewer facility alignment, including the horizontal alignment of stubs (no matter the length of the stub). For stubs either the location of the manhole the stub is to serve or the angle from the out-going pipe must be shown.
 - (c) Labeling of all Type 2 and Type 3 clean-outs including Top of Casting (TC) elevations.
 - (d) All proposed or existing easements and right-of-ways. Existing easements and right-of-ways must also indicate the name of the grantee(s) and instrument number.
 - (e) Streets and street names.
 - (f) Lot lines and lot numbers.
 - (g) Storm sewers and structure numbers.
 - (h) All other utilities including overhead lines and their support poles and or support towers, underground vaults, signal poles and electrical transformers/switch gear.
 - (i) Existing water, gas or oil wells within two hundred (200) feet of sanitary sewer facilities.
 - (j) Septic fields.
 - (k) Existing fence lines.
 - (l) Access drives.
 - (m) Earth filters.
 - (n) Match lines.
 - (o) If a lateral crosses a storm sewer then provide the invert elevations of the lateral and storm sewer.
 - (p) *If a lateral crosses a water main then provide the invert elevations of the lateral and water main at the point of crossing. In addition provide the invert elevation of the lateral at its terminus.*
 - (q) Concrete cradles.

- (r) For off-site sewers not displayed on the Site Development Plan, the plan view must indicate all items required on a Site Development Plan. Refer to Site Development Plan, previously described in this section of these Design Specifications.
- 3) The profile must include the following:
- (a) Sanitary sewer structure numbers.
 - (b) Sanitary sewer facility alignment.
 - (c) If air/vacuum relief valves are installed, then identify the valves as air/vacuum or air only.
 - (d) Accurately indicate existing and proposed grade lines, especially considering mounding, street crossings and low points.
 - (e) Diameter of pipe.
 - (f) Length of sanitary sewer facilities.
 - (g) Slope of pipe.
 - (h) Type and wall thickness class of pipe (For example, PVC SDR 35, Ductile Iron Class51). If the pipe designation is other than ASTM D-3034, then provide the appropriate designation. For example, ASTM D-2241, ASTM F-679, AWWA C-900, AWWA C-905, etc.
 - (i) All storm sewer and utility crossings with size and type of pipe and invert elevations *for both*. For force mains also provide the invert elevation of the force main at the crossing.
 - (j) Concrete cradles.
 - (k) Granular backfill with stationing.
 - (l) Elevations on the profile grid.
 - (m) Profile views must show complete runs of pipe that is from manhole to manhole. The orientation must be approximately the same as the plan view above the line profiled.
- B. The originating and at least one (1) local benchmark (within one thousand (1000) feet of the boundary of the Project) with a concise description and basis of vertical datum (NAVD 1988). The originating benchmark must be an HSE approved vertical control monument detailed in HSE's "Horizontal and Vertical Control Data". Benchmark information is available upon request from Engineer.
- C. The horizontal location of all sanitary sewers, manholes, wyes, laterals, lift stations (wet well and valve vault), force mains, air/vacuum relief manholes, isolation/service valves, force main/lateral clean-outs and special structures (including, grease traps, grit traps, oil/water separators, neutralization tanks, etc.).
- D. The plan view must indicate the proposed wye station (from the center of the nearest downstream manhole) and lateral length for all laterals proposed to be constructed with the Project. Note: If a lateral connects directly into a manhole and was approved by Engineer,

then indicate the station as “Out of manhole”.

- 1) If common laterals are approved by the Engineer then provide wye station along main and length of common lateral. Provide station from main to individual service Lateral fitting and length from fitting to terminus.
- E. The plan view must indicate the lot number or building designations (number, address, name, etc.) for each wye and lateral proposed to be constructed with the Project.
- F. The plan view must show the complete boundary of any parcel or lot serviced by laterals connected to the sewer identified on the profile view.
- G. All sanitary sewer manhole and lift station top of casting/invert elevations, air/vacuum relief manhole, isolation/service valves, grinder/effluent pumps, I&A tanks, force main/lateral clean-out and special structure (including, grease traps, grit traps, oil/water separators, neutralization tanks, etc.) top of casting elevations, force main and force main fitting elevations, upstream invert elevation of stubs (if longer than twenty (20) feet), distances and slopes must be displayed as follows:
- 1) All elevations provided must be on the NAVD 1988 datum.
 - 2) Provide the as-built top of casting and all invert elevations of existing tie-in manholes. Also provide the size, type (with wall thickness class) and direction of connection for all pipes.
 - 3) All invert elevations of stub, top and bottom drop, lateral (if approved) and force main connections must be provided for all sanitary sewer structures.
 - 4) All invert elevations must indicate the direction of connection (east, west, etc.).
 - 5) If a structure appears multiple times in the Construction Plans, then all top of casting and invert elevations must be provided in each profile.
 - 6) A vertical elevation must be provided every five hundred (500) feet (maximum interval), at all fittings (ells, tees, valves and adapters) and low points for all force mains.
 - 7) If a stub (twenty (20) feet or longer) is installed, then an invert elevation must be provided in the manhole and at the upstream invert of the stub.
 - 8) All top of casting and invert elevations must be indicated to the hundredth of a foot and display all significant digits. For example, 80.05 is not acceptable. It must read 780.05. Note: Proposed top of casting elevations can be indicated to the tenth of a foot.
 - 9) All distances must be measured from center of manhole to center of manhole and be rounded to the nearest foot.
 - 10) All slopes must be rounded to the hundredth of a percent.
- H. If a sanitary sewer manhole is going to be removed when sanitary sewer facilities are

extended then:

- 1) In the plan view, indicate the next downstream manhole.
 - 2) In the profile, indicate the next downstream manhole with as-built top of casting and invert elevations.
 - 3) In the profile, provide pipe information (size, type and class, distance, slope, etc.) for both the manhole to be removed to the next upstream manhole and the next downstream manhole to the next upstream manhole.
- I. In the profile, the diameter and direction of connection (east, west, etc.) of all non-profiled pipes must be provided in each manhole.
- J. In the profile, the pipe type and wall thickness class must be indicated for all stubs *with invert elevations*, no matter the length.
- K. *In the profile no match line between manholes on different sheets. All sheets must provide a manhole to manhole profile.*
- L. When main line gravity sewers have less than five (5) feet of vertical cover (from grade to the crown of the pipe) then:
 - 1) The profile must graphically indicate any concrete capping or encasement.
 - 2) Add an easily identifiable note to the profile near the appropriate stations which states, “(provide linear footage) +/- feet of concrete cap/encasement is required from station (provide beginning station) to (provide ending station)” to the respective sheet.
- M. When laterals have less than five (5) feet of vertical cover (from grade to the crown of the pipe) as calculated using Engineer’s method described in Cover of the Design Requirements section of these Design Specifications, then:
 - 1) The plan view must label the concrete and graphically indicate any concrete capping or encasement.
 - 2) Add an easily identifiable note to the plan view near the appropriate lot/building which states, “The laterals servicing (provide lot number or building name) must be installed at maximum depth. Depending on cover, the laterals may require concrete capping or encasement from (provide beginning station) to (provide ending station).” to the respective sheet.
- N. When wyes are installed on main line sewers at an Ultimate Depth (from grade to invert) of twelve (12) feet or greater, then:
 - 1) The plan view must label the concrete and graphically indicate the concrete capping.
 - 2) Add an easily identifiable note to the plan view near the appropriate lot/building which states, “Depending on cover, the wye servicing (provide lot

number or building name) shall be concrete capped.” to the respective sheet.

- O. Graphical representation of all bores related to the installation of sewer facilities. Indicate bores in the profile and add an easily identifiable note (depending on the type of bore) to the respective sheet which states the following:
- 1) For bores with casings, “A (provide size) inch casing is required from station (provide beginning station) to (provide ending station). Upon completion of the bore, invert elevations must be provided to a SAMCO inspector.”
 - 2) For directional bores, “A directional bore is required from station (provide beginning station) to (provide ending station). Upon completion of the bore, invert elevations must be provided to a SAMCO inspector.”
- P. Graphical representation of fittings proposed to transition from one type of pipe to another. Indicate fittings in the profile and add an easily identifiable note to the profile which states, “A transition fitting (ductile iron, MJ solid sleeve with transition gaskets) is required at station (provide station)” to the respective sheet.
- Q. All stationing must reference the center of the nearest downstream manhole.
- R. Required notes on all Plan and Profile sheets (Gravity and Force Main).
- 1) “Manhole or clean-out castings may need to be elevated after final grading to insure drainage away from structures.”
 - 2) “Pavement or concrete, including driveways and sidewalks, must not be constructed on or within one (1) foot horizontal distance of sanitary sewer castings.”
 - 3) “All rough grading (on-site and off-site) must be finished to within one (1) foot of final grade prior to the start of construction of the sanitary sewer infrastructure.”
 - 4) “All laterals shall terminate within a sanitary sewer easement.”
 - 5) “At the inspector’s discretion, a concrete cradle may be required for all lateral/utility crossings.”
 - 6) “Contractor must field verify invert elevations of existing manhole prior to construction. If a variation exists, then contact SAMCO.” Note: This note must appear in the profile adjacent to all existing manholes.
- S. Required notes on all Gravity Plan and Profile sheets.
- 1) “Sanitary sewer facilities, including mains and laterals, must maintain five (5) feet of cover from the top of pipe to grade. If adequate cover can not be maintained, then concrete capping must be installed when cover is four (4) to five (5) feet and concrete encasement must be installed when cover is three (3) to four (4) feet. Under no circumstances will cover be permitted to be less than three (3) feet.”

- 2) "All bench walls shall extend to the crown of the highest influent pipe."
- 3) *"The tee wyes located on the sanitary sewer mainline must be designated and installed to obtain a 1:1 ratio away from manhole structures (depth of manhole: distance of tee wye from manhole), due to problems encountered in the field with the tee wyes failing when located in the over dig of manholes."*

T. Required notes on all Force Main Plan and Profile sheets.

- 1) "The as-built elevation of the base material must be verified by an appropriately registered Indiana professional prior to the setting or pouring of the wet well base. Provide as-built elevation to SAMCO and Design Engineer."
- 2) "Force mains must maintain 4.5 feet of cover from the top of pipe to grade. Under no circumstances will cover be permitted to be less than 4.5 feet."
- 3) "Force mains must be constructed at a constant positive slope from low points and clean-outs to air/vacuum relief valves."
- 4) "All force main fittings (four (4) inches or larger) must be ductile iron and all bends must be 45 degrees or less."
- 5) "A horizontal location and vertical elevation is required every 500 feet (maximum interval), at all fittings (ells, tees, valves, adapters, etc) and low points of the force main. If as-built information is not provided, then the contractor must excavate the force main to provide the necessary as-built information."
- 6) "Contractor must install tracer wire, insulated #10 copper, immediately adjacent to the top of the force main. Tracer wire must extend to the surface at all structures and fiberglass field markers." The tracer wire must extend through all air/vacuum relief manholes and wire is to be tied to top step.
- 7) "Contractor must install "marker balls" directly above the force main, no deeper than three (3) feet below finish grade, at two hundred fifty (250) feet on straight runs and above all fittings where the direction of the pipe changes."
- 8) "Contractor must provide #8 stone bedding above and below the force main, with at least three (3) inches of sand that must be placed as a cushion around the force main, wherever construction is below the water table or unstable soil conditions are encountered."

U. Miscellaneous notes

The following easily identifiable notes must appear on the respective Plan and Profile sheets in the following situations:

- 1) If any portion of the existing sanitary sewer facilities (laterals, manholes, sewers, force mains, etc.) is to be disconnected or removed, then add "Contractor shall (describe what and how the sewer facility is to be removed or disconnected.)" to the respective sheet.
- 2) If watertight bolted and gasketed manhole castings are to be installed, then add

- “Watertight bolted and gasketed castings are required for MH’s # (provide manhole numbers).” Add this note to the profile near the respective manhole.
- 3) If manhole top of castings are constructed above finished grade (usually to be eighteen (18) inches above the current DNR 100 year flood elevation of surrounding water ways), then add “Contractor to construct mound with five (5) foot radius around manhole. Side slopes must be 3:1.” Add this note to the profile near the respective manhole.
 - 4) If pipe bollards are to be constructed around manholes, then add “Contractor to construct pipe bollards around MH’s # (provide manhole numbers).” Add this note to the profile near the respective manhole.
 - 5) If a new manhole is added onto an existing sewer, then add “Construct new manhole per HSE’s Gravity Sanitary Sewer Details sheet with ductile iron fittings. A “saddle” or “dog house” structure will not be permitted. Contractor to low pressure air and deflection test the entire segment of existing sewer, both sides of the new manhole, and vacuum test the new manhole while maintaining continuous service. Segmentation of the line may be required if existing customers are connected into the sewer.” Add this note to the profile near the respective manhole.
 - 6) If an existing manhole needs to be cored, then add “Contractor to core existing manhole and install Press Wedge II boot. Contractor must contact SAMCO after completion of first joint to obtain as-built invert elevation of the core. After completion of work, contractor must vacuum test manhole.” Add this note to the profile near the existing manhole.
 - 7) If future on-site or off-site extensions may be connected to a structure, then add “Contractor must install the steps on the (provide astronomical direction) side of MH# (provide manhole number) to avoid conflicts with future extensions.” Add this note to the profile near the respective manhole.
 - 8) For cored holes, penetrations and/or other opening through a manhole or other sanitary structure, if a separation of less than eighteen (18) inches exists between the outer edge of resilient connectors, then add “The re-bar or mesh area must be increased on the (provide astronomical direction) side of MH # (provide manhole number) to suit the specific application as deemed necessary by Engineer.” Add this note to the profile near the respective manhole.
 - 9) If an existing manhole top of casting needs to be adjusted and the adjustment involves more than just installing or removing adjusting rings, then add “Contractor to vacuum test MH # (provide manhole numbers) after top of casting is adjusted. Until final build out, a minimum of one (1) 4” adjusting ring must be installed on each manhole.” Add this note to the profile near the respective manhole.
 - 10) If a manhole needs to be installed with a diameter greater than four (4) feet, then add “Contractor to provide (provide diameter) foot diameter base and barrel sections for MH #’s (provide manhole numbers).” Add this note to the

- profile near the respective manhole.
- 11) If a manhole needs to be installed as a fiberglass structure, then add “Contractor to install MH #'s (provide manhole numbers) as a one piece fiberglass reinforced polyester manhole. Contact SAMCO for specifications.” Add this note to the profile near the respective manhole.
 - 12) If a clean-out is added to a gravity main in place of a manhole, then add “Prior to adding the elbow for the clean-out, contractor must coordinate with surveyor to obtain as-built invert elevation.” Add this note to the profile near the clean-out.
 - 13) If a stub greater than twenty (20) feet is installed in a manhole, then add “Prior to backfilling, contractor must coordinate with surveyor to obtain an upstream as-built invert elevation and accurate horizontal location. Contractor to mark end of stub location with a painted green 2” x 4”.” Add this note to the profile near the manhole or stub.
 - 14) If a lateral is connected to a shallow (less than twelve (12) feet) manhole to avoid connection onto an interceptor, then add “Contractor to core existing manhole for the lateral servicing lot (provide lot number) and install Press Wedge II boot. The bench wall must be formed to receive flow from the lateral.” Add this note to the profile near the respective manhole.
 - 15) If a lateral is connected to a deep (greater than twelve (12) feet) manhole to avoid connection onto a deep interceptor, then add “Contractor to core existing manhole for the lateral servicing lot (provide lot number) and install Press Wedge II boot. The bench wall must be formed to receive flow from the lateral. The lateral and fittings must be ductile iron class (provide wall thickness class) pipe until after the 45 degree elbow fitting within eight (8) feet of final grade.” Add this note to the profile near the respective manhole.
 - 16) If a lateral is connected onto a sewer with an Ultimate Depth of twenty (20) feet or greater, then add “Contractor must install the entire lateral servicing lots (provide lot numbers) with PVC SDR 23.5 pipe.” Add this note to the plan view near the respective lateral.
 - 17) If an end run manhole is to be installed and the manhole has no stubs and will be extended in the future, then add “MH # (provide manhole number) must be installed without a bench wall.” Add this note to the profile near the respective manhole.
 - 18) If an end run manhole is to be installed and the manhole will not be extended in the future, then add “Bench wall must extend across the entire width of MH # (provide manhole number) with a grouted flow transition at far wall to the top of bench wall.” Add this note to the profile near the respective manhole.
 - 19) If a flow monitoring or sampling device is to be installed in a manhole, then add easily identifiable notes to the respective sheet detailing the Flow Monitoring Considerations and/or Sampling Considerations described in Sanitary Sewer Manholes under the Design Requirements section of these

Design Specifications. Add this note to the profile near the respective manhole.

- 20) If a force main connects into a wye, then add “Contractor to install a plug valve at station (provide station along the force main) to allow for testing of the force main. The valve box shall be lettered ‘Sewer.’” Add this note to the profile near the wye connection.
- 21) If a common force main will be installed, then add “Contractor must install a service valve adjacent to the main line force main for each connection; however, the service valve box shall not be installed until final grading of the lot or parcel and connection of the home or building. A painted green 2” x 4” shall mark the location of the service valve. Isolation valve boxes must be installed at the time of initial construction; however, castings may need to be adjusted after final grading. Each connection must also be installed with an I&A tank as approved by Engineer.” Add this note to the required notes section.
- 22) If a home or building is serviced by an I&A Tank, a grinder pump or effluent pump and the service line is greater than fifty (50) feet, then add “Contractor must install tracer wire, insulated #10 copper, immediately adjacent to the top of the service force main. Tracer wire must extend to the surface at the service valve box and wet well.” Add this note to the plan view near the respective lot.
- 23) If a lift station is installed, then add “Upon completion of the lift station site, contractor must coordinate installation of the lift station property corner monuments (capped re-bar) with Design Engineer.” Add this note to the plan view near the lift station.
- 24) If a lift station is installed, then add “Contractor must coordinate capping of de-watering well points at grade with SAMCO.” Add this note to the profile near the lift station.
- 25) If a lift station is installed then add “Contractor shall provide a coating as approved by the Engineer to the wet well interior.” Add to profile near lift station.
- 26) *For the force main discharge to gravity sewer add “Contractor shall provide a coating as approved by the Engineer to the interior of any manhole with in five hundred (500) feet either up stream or down stream of the point at which the force main is discharged.” Add to profile near discharge point.*
- 27) If a lift station is installed, then add “The valve vault shall be provided with an extendable access ladder/handrail.” Add to profile near lift station.
- 28) If the minimum separations from water supplies to sanitary sewer facilities required by 327 IAC 3-6-9 can not be maintained, then add “The sewer from (provide beginning station) to (provide ending station) must be constructed as PVC pressure rated pipe per ASTM D-2241, 160 psi pipe - SDR 21. Transition to and from ASTM D-3034 to D-2241 must be with ductile iron,

MJ solid sleeve fittings with transition gaskets.” Add this note to the profile near the respective location. Note: This is applicable for 6” to 12” pipe. For larger diameter pipe contact Engineer for the appropriate note.

- 29) If construction of the sanitary sewer facilities crosses a legal drain, then add “Contractor must contact Hamilton County Surveyor’s office 48 hours prior to the crossing of (provide name of legal drain) to schedule an inspection. Contractor must also comply with the Utility Installation Cross Section and Open Drain Crossing Details issued by the Hamilton County Surveyor’s Office.” Add this note to the profile near the legal drain crossing.
- 30) If construction of the sanitary sewer facilities crosses a water way which is not a legal drain, then add “Contractor to install 6” hand laid rip/rap along trench width from top of bank to top of bank.” Add this note to the profile near the water way crossing.
- 31) If the sanitary sewer facilities trench is going to be constructed across an existing structure where debris could be a problem, then add “Contractor shall use extreme care while excavating near the existing (provide a description of the structure) so that no building debris will be used as backfill.” This note should appear in the profile at the station of the existing structure.
- 32) If the sanitary sewer facilities trench is going to be constructed across an existing high pressure gas line or other pipeline, then add “Contractor must maintain a minimum vertical separation of two (2) feet (from outside of pipe to outside of pipe) between the pipeline and sanitary sewer infrastructure. Contractor must coordinate the crossing with the pipeline owner.” This note should appear in the profile at the station of the crossing.
- 33) If the sanitary sewer facilities trench is going to be constructed above existing grade, then add “Contractor to provide 95% modified proctor compaction of suitable fill in six (6) inch lifts or excavate to undisturbed soil and bed with #8 stone for all portions of sanitary sewer infrastructure designed above existing grade.” This note must appear in the profile adjacent to all such areas.
- 34) If portions of the sanitary sewer facilities are to be a Private sanitary sewer system, then add “MH # (provide manhole number) to MH # (provide manhole number) is a private sanitary sewer system and will not be conveyed to HSE. Therefore, “Private” castings are required for MH’s # (provide manhole numbers).” Add this note to the profile near the respective segments of Private sewer.
- 35) If a lateral is being extended more than two hundred (200) feet after the original installation, then add “In order to allow for testing of the lateral, contractor must install glue-on caps above grade on all type 2 or 3 clean-outs. During testing, contractor must provide adequate bracing to prevent blow-out of riser. After completion of an acceptable low pressure air test, contractor must then remove the glue-on caps and install the type 2 or 3 clean-out.” This note should appear in the plan view near the appropriate lateral.

- 36) If laterals are designed with less than fifteen (15) feet of horizontal separation from storm structures, then add “The laterals servicing lots (provide lot numbers) must be installed to maintain a minimum horizontal separation of ten (10) feet from all storm structures.” Add this note to the plan view near the respective lateral.
- 37) If off-site laterals are being installed, then add “Contractor must install all off-site laterals with a minimum cover of six (6) feet from the top of pipe to grade.” Add this note to the plan view near the respective lateral. Note: Laterals will be considered off-site if they are constructed in an area that will not be platted immediately following construction Completion.
- 38) If wyes are installed on an existing sanitary sewer system, then add easily identifiable notes to the respective sheet detailing the considerations described in Laterals under the Design Requirements section of these Design Specifications. Add these notes to the plan view near the respective lateral.
- 39) If access drives are to be constructed, then add “Construct all access drives per HSE’s Lift Station Access Drive detail on sheet (provide sheet number).” Add this note to the plan view near the access drive.
- 40) If a gate is to be installed at a fence crossing, then add “Contractor shall install gate and coordinate with SAMCO as to the direction the gate opens. Gate shall be installed with a hasp for use with a HSE approved lock. Contractor shall purchase pad lock from HSE.” Add this note to the plan view near the fence crossing.
- 41) If the sanitary sewer facilities are to be constructed across a wooded easement, then add “All trees and brush must be removed within the entire limits of the sanitary sewer easement.” Add this note to the plan view near the respective location.

7.08 - Lift Station Plan Sheet

- A. Add the appropriate copy of HSE’s Duplex, Initial Triplex or Triplex Lift Station Plan.
- B. Complete the Lift Station Information section.
- C. Provide dimensions in the Dimension Chart.
- D. Provide elevations in the Elevation Chart.
- E. Add a Lift Station Site Plan:
 - 1) Wet well and valve vault orientation.
 - 2) Control panel location.
 - 3) Fencing and gate locations.
 - 4) Asphalt access drive from public right-of-way.

- 5) Parking stops.
- 6) Grading and drainage arrows.
- 7) Boundary of lift station parcel to be granted to HSE.
- 8) Odor control facilities.
- 9) Area for emergency generator.
- 10) Limits of compacted #53 stone and polyethylene film (if required by the site orientation).
- 11) All other information that will allow for a detailed review of the site plan.

7.09 - Storm Sewer Plan and Profile Sheets

- A. Storm Sewer Plan and Profiles must be included with each set of Construction Plans submitted for approval.
- B. Indicate all sanitary sewer facility crossings with size and type of pipe and invert elevation.
- C. Indicate concrete cradles required at sanitary sewer facility crossings, including laterals. Engineer will not permit the installation of concrete cradles on force mains.
- D. Add an easily identifiable note which states, "Except for force mains, contractor to install concrete cradles when the vertical separation (as measured from the exterior of the pipes) between sanitary sewer facilities and storm sewers is 18" or less".

7.10 - Detail and Specification Sheets

- A. Add HSE's entire Gravity Sanitary Sewer Details sheet to all Projects involving the construction of gravity sewers or manholes.
- B. Add HSE's entire Lift Station & Force Main Details sheet to all Projects involving the construction of lift stations or force mains.
- C. Add the appropriate copy of HSE's Initial Triplex or Triplex Electrical Diagram.
- D. If requested by Engineer, specific details may need to be added to the construction drawings when the Project includes the construction of special structures affecting the sanitary sewer facilities. These details may have already been created by Engineer or may need to be generated by Design Engineer and approved by Engineer.
- E. Add HSE's entire Sanitary Sewer Specifications sheet to all Projects involving the construction of gravity sewers or manholes.
- F. Add HSE's entire Lift Station & Force Main Specifications sheet to all Projects involving the

construction of lift stations or force mains.

- G. Add HSE's entire Directional Bore Specifications sheet to all Projects involving Directional Bore type construction.
- H. If requested by Engineer, additional specifications may need to be added to the construction drawings when the Project includes special construction situations affecting the sanitary sewer facilities. These specifications may have already been created by Engineer or may need to be generated by Design Engineer and approved by Engineer.

7.11 - Shop Drawings

- A. Provide shop drawings of special structures affecting the sanitary sewer facilities including lift station pumps and equipment, grease traps, grit traps, oil/water separators, neutralization tanks, etc.
- B. Shop drawings will need to be reviewed and approved by Engineer prior to Construction Plan approval.
- C. Special structures that are installed without prior approval (regarding manufacturer, model number, size, capacity, configuration, etc.) from Engineer may be required to be removed and constructed as specified in the approved shop drawings. Therefore, Subscriber and Design Engineer shall thoroughly review the impact of the special structures to the Project.
- D. HSE will perform field inspections after final build-out to verify compliance with the approved shop drawings.

7.12 - Architectural Plans

A **complete** set of architectural plans must be submitted for all buildings/structures to be constructed so that Engineer can thoroughly understand the intended use of the proposed structure and determine the projected number of EDU's. The Engineer's primary focus will be with the following sheets:

A. Floor Plan:

- 1) Label or describe the use of each Room.
- 2) Indicate a seating configuration.
- 3) Provide building or structure numbers.
- 4) Provide the finished floor elevation.
- 5) Provide a floor plan for each building or structure to be constructed.

B. Plumbing Plan:

- 1) Indicate plumbing layout with proposed floor plan.

- 2) Label all fixtures.
- 3) Indicate special structures affecting the sanitary sewer facilities including grease traps, grit traps, oil/water separators, neutralization tanks, etc.
- 4) Indicate the appropriate (either Type 1, 2 or 3) external clean-out(s).
- 5) Indicate external plumbing as six (6) inches.
- 6) Indicate the exit point of the lateral consistent with the Site Development Plan and Plan and Profile sheets.
- 7) Indicate the invert elevation of the lowest point to have gravity sanitary sewer service. Design Engineer should carefully consider the lowest elevation. For example, the invert of trench drains or the outlet of swimming pool sump pits may be the lowest point.
- 8) Indicate plumbing isometrics with fixtures labeled.
- 9) Indicate building numbers.
- 10) Provide a plumbing plan for each building or structure to be constructed.

C. Equipment Plan - Provide description, quantity, manufacturer and model number of proposed equipment.

D. Shop Drawings - Refer to Shop Drawings under the Construction Plan Documentation section of these Design Specifications.

7.13 - Landscaping, Site Lighting and Other Related Plans

A. Landscaping plans must indicate the following:

- 1) All existing and proposed plants (trees, shrubs, flowers).
- 2) The drip line of all trees.
- 3) Retaining/landscaping/entrance walls.
- 4) Fencing.
- 5) Mounding.
- 6) Site lighting.
- 7) Signs.
- 8) Irrigation lines, etc.

B. Add easily identifiable notes to all sheets of the landscaping plans which state the following:

- 1) Prior to the installation of landscaping, landscaping contractor must schedule a pre-construction meeting with SAMCO, the construction manager and any other affected party to discuss proper separations from the sanitary sewer facilities.
- 2) Owner *may* place or permit to be placed any trees or other deep rooted landscaping *with separation as specified in the current (at the time of planting) HSE Approved Tree List. For trees not listed in the HSE Approved Tree List a minimum separation of ten (10) foot horizontal distance from*

Laterals or any other sanitary sewer facilities (as measured from the drip line of the mature *tree* to the center of sanitary sewer facilities) *must be maintained*. Any trees or landscaping placed within easements or right-of-ways are at risk of being damaged or removed by HSE without the obligation of replacement.

- 3) The toe of slope of earthen mounding can not be placed within ten (10) feet horizontal distance of sanitary sewer mains, laterals or manholes.
- 4) Retaining/decorative/entrance walls can not be placed within ten (10) feet horizontal distance of sanitary sewer mains, laterals or manholes.

C. Add easily identifiable notes to all sheets of the site lighting and related plans which state that, lighting, signs, irrigation lines, etc. must be constructed to maintain a minimum horizontal separation of ten (10) feet from the center of the sanitary sewer facilities.

7.14 - Revisions

- A. Revision blocks must be filled out for all subsequent (after the original set of Construction Plans) sets submitted to HSE for approval. The revision block must reflect all changes (including, but not limited to, grading/earthwork, storm sewers, streets/sidewalks, other utilities, landscaping, site lighting, signs, etc.) to the construction documents.
- B. All easement revisions must appear on the plat, Site Development Plan, respective Plan and Profile sheets and all other affected sheets.
- C. All revisions to top of casting and invert elevations must be noted on the respective Plan and Profile sheets, structure table (if a table is used) and all other affected sheets.
- D. All revisions of sanitary/storm sewer orientation must appear on the Site Development Plan, respective Plan and Profile sheets (plan view and profile) and all other affected sheets.
- E. All storm/sanitary sewer crossing revisions must appear on the respective Plan and Profile sheets (revised invert elevations in the profile) and all other affected sheets.
- F. PPR fees are charged for review of the original submittal of the Construction Plans, generation of a comment review letter (if necessary) and then review of a second set of Construction Plans. If Engineer is required to generate subsequent comment review letters, then Subscriber will be charged additional Construction Plan review fees.
- G. To expedite the approval process, Engineer recommends that a letter, detailing the actions taken in response to each item of the comment review letter, accompany each set of revised Construction Plans.

H. Each set resubmitted must include one (1) complete set of Construction Plans with supporting documentation. Design Engineer shall deliver resubmitted sets to HSE at its respective business address.

7.15 - Construction Plan Approval

- A. Approval will not be issued until all sheets of the Construction Plans comply with these Design Specifications and all issues of the comment review letters are resolved.
- B. Approval will be evidenced by an “Approved - Hamilton Southeastern Utilities, Inc.” date stamp on the construction drawings.
- C. Design Engineer must receive formal written approval from Engineer. At this time, Design Engineer must supply Engineer with five (5) complete sets of construction drawings for distribution to the Engineer’s inspectors and Contractor.
- D. Plan approvals will be valid for a period of six (6) months from the date of the approval stamp. After the date of expiration, HSE reserves the right to require revisions to approved Construction Plans based on the most current design standards, details, specifications and master plan.
- E. Construction Plan approval does not relieve the Subscriber, Design Engineer or Contractor from any requirements of HSE’s standards, specifications, details, etc.
- F. Refer to Initiation of Construction under the General section of these Design Specifications for further information.

7.16 - Record Drawings

- A. HSE may withhold connection permits if record drawings in accordance with HSE’s “Sanitary Sewer Completion Specifications” are not received in a timely manner.
- B. Refer to HSE’s “Sanitary Sewer Completion Specifications” for further information.
- C. Refer to Completion Documentation under the General section of these Design Specifications for further information.

SECTION 8 - IMPROVEMENT LOCATION PERMITS (“ILP”)

For the purpose of these Design Specifications, ILPs are all other Projects except single family residential subdivisions.

8.01 - General Requirements

- A. Comply with all applicable items previously mentioned in these Design Specifications.
- B. Comply with HSE's "Rules and Regulations".
- C. Changes of grade over existing sanitary sewer facilities will not be permitted, unless approved, in writing, by Engineer.
- D. Include a Site Development Plan. Refer to Site Development Plan under the Construction Plan Documentation section of these Design Specifications. In particular, the following items will be important:
 - 1) The location of all proposed or existing sanitary sewer facilities.
 - 2) The entire overall boundary of the Project.
 - 3) All structures including buildings, pools, playing fields, etc.
 - 4) All asphalt or concrete surfaces including parking lots, sidewalks, etc.
 - 5) Graphical representation of all existing or proposed easements (sanitary sewer or otherwise) and right-of-ways within the boundary of the Project with their corresponding instrument numbers.
 - 6) Proposed grading.

8.02 - Architectural Requirements

- A. Comply with the most recent edition of HSE's "Design and Construction of Laterals".
- B. Engineer will not permit sources of clear water discharge into the sanitary sewer facilities. This includes but is not limited to the following:
 - 1) Foundation/footing drains,
 - 2) Sump pumps with foundation drains or other clear water sources,
 - 3) Roof drains,
 - 4) Heat pump/Geo-Thermal discharge,
 - 5) Cooling water,
 - 6) Trench/floor drains subject to storm water run-off and/or,
 - 7) Any other sources of clear/unpolluted water.
- C. If a room contains a floor drain or trench drain and has an exterior door, then the entrance to the room must have a either a three (3) inch sill or ramp to prevent storm water from entering the sanitary sewers. The sill or ramp must be indicated in the Construction Plans.
- D. All external concrete or pavement must slope away from the building or structure at maximum grade consistent with ADA requirements. This must be noted in the Construction Plans.

- E. Upon exiting the building, the lateral must maintain a minimum cover (from finished grade to top of pipe) of two (2) feet. Cover must then increase to a minimum of three (3) feet, immediately downstream of the building's exterior clean-out. Laterals with less than two (2) feet of cover at the building will not be accepted by HSE.
- F. The pipe size, invert elevation at the building and location of the lateral must be consistent between the Site Development Plan, Plan and Profile sheets and the Plumbing Plan.
- G. Refer to Shop Drawings, Architectural Plans and Landscaping, Site Lighting and Other Related Plans under the Construction Plan Documentation section of these Design Specifications.

8.03 - EDU Calculation

- A. Include two (2) **complete** sets of architectural plans for all existing or proposed buildings/structures so that Engineer can thoroughly understand the intended use of the proposed buildings and determine the projected number of EDU's.
- B. For an existing building/structure supply two (2) years of water consumption data. If the building/structure is to be constructed, then supply two (2) years of water consumption data from two (2) similar buildings (square footage, number of employees, equipment, etc.).
- C. Identify all equipment that will directly or indirectly drain into the sanitary sewers. Provide water consumption data on the equipment.
- D. House keeping procedures. For example, wash down of equipment.
- E. Provide the number of full time and part time employees working at the facility in a twenty-four (24) hour period. For schools, provide the current and future student body.
- F. To assist in the permitting process, Subscriber shall provide a list on legal or letter size paper indicating the following:
 - 1) For apartment complexes - A list of building numbers with the proper number of units. The list shall also include all other buildings (for example clubhouses, maintenance buildings, etc.) being connected to the sanitary sewer facilities.
 - 2) For strip malls - A list of tenants (company name) with the name and phone number of the contact person.
 - 3) For other uses - To be determined.
- G. EDU assessments are contingent upon approval by the respective municipality.

- H. HSE may require that a Sewer Service Agreement be recorded against the deed of the Project for payment of the monthly sewer fees.

8.04 - Existing Buildings/Structures and the Connection of Existing Sewers

- A. Provide the elevation of the lowest point in each building/structure to have gravity sanitary sewer service. Is this elevation one (1) foot above the lowest top of casting elevation of either the first upstream or downstream manhole on the sewer to which the connection is to be made? Refer to Sanitary Sewer Manholes (Top of Casting Elevation) in the Design Requirements section of these Design Specifications.
- B. Design Engineer must conduct a site investigation to identify all possible sources of clear water discharge. For example:
 - 1) Foundation/footing drains,
 - 2) Sump pumps with foundation drains or other clear water sources,
 - 3) Roof drains,
 - 4) Heat pump/Geo-Thermal discharge,
 - 5) Cooling water,
 - 6) Trench/floor drains subject to storm water run-off and/or,
 - 7) Any other sources of clear/unpolluted water.
- C. Identify the location(s) in which the plumbing exits the building/structure.
- D. Engineer will require testing to determine potential sources of inflow/infiltration (“I/P”). Therefore, all existing sanitary sewer facilities, which are to remain in service, shall be televised. Based on the review of the television tapes by Engineer, additional testing such as smoke testing, low pressure air testing, die testing, vacuum testing, etc. may be required. If the sanitary sewer facilities do not pass these tests, then repairs or replacement may be required to bring the infrastructure into compliance.
- E. Provide record drawings and/or shop drawings in accordance with HSE’s “Sanitary Sewer Completion Specifications” for all existing sanitary sewers that will connect into HSE’s sanitary sewer facilities.
- F. Identify areas serviced by special structures affecting the sanitary sewer facilities including grease traps, grit traps, oil/water separators, neutralization tanks, etc. Provide a shop drawing or detail for each structure.
- G. Special structures affecting the sanitary sewer facilities including grease traps, grit traps, oil/water separators, neutralization tanks, etc. must be cleaned and/or pumped out prior to being connected to HSE’s sanitary sewer facilities.

- H. For a single family residence requiring only a lateral extension, Design Engineer must provide a plot plan with all pertinent information required by these Design Specifications.
- I. If other than single family residential, then provide two (2) complete sets of architectural plans for all existing buildings/structures.
- J. Engineer may perform a field inspection to identify areas of concern when existing buildings, existing sanitary sewers or special structures (including grease traps, grit traps, oil/water separators, neutralization tanks, etc.) are connected to HSE's sanitary sewer facilities.
- K. Design Engineer is reminded that the on-site waste water disposal system must be closed per state and local requirements. HSE and Engineer will not review or enforce the proposed closure process.

8.05 - Sources of Contamination

- A. Design Engineer must identify all potential sources of contamination that could enter the sanitary sewer facilities. For example, contamination from above ground/underground fuel tanks, fuel oil from boilers, chemicals associated with boiler or cooling systems, neutralization tanks, etc.
- B. Engineer may request information on the strength of the effluent and the characterization of constituents. For example, BOD, TSS, NH₃, TPH, oil/grease, etc.
- C. Engineer may request copies of the Material Safety Data Sheets (MSDS), quantities, discharge rates, temperature, pH, etc. for all chemicals stored on-site.
- D. To prevent contaminants from entering the sanitary sewer facilities, dikes may be required around floor drains or trench drains.
- E. Refer to HSE's "Rules and Regulations" as to sources of contamination.

8.06-Pools

- A. Supply two (2) sets of swimming pool plans with cross sections of the pool and a layout of the surrounding pool/deck area.
- B. If applicable, supply the flow rate of the peak filter backwash.
- C. If the pump house is a separate building from the clubhouse, then two (2) laterals will need to be installed.

D. Supply restroom/locker room floor plans with the number of showers, water closets, urinals, lavatories, etc.

NOTE:
 IN BOTH INSTANCES
 GIVE 3 WYE STATIONS
 AND 3 LENGTHS

COMMON LATERAL: 0+50, 100'
 LOT 4: 0+95, 20'
 LOT 5: 0+90, 20'

COMMON LATERAL: 0+75, 100'
 LOT 6: 1+00, 25'
 LOT 7: 1+00, 20'

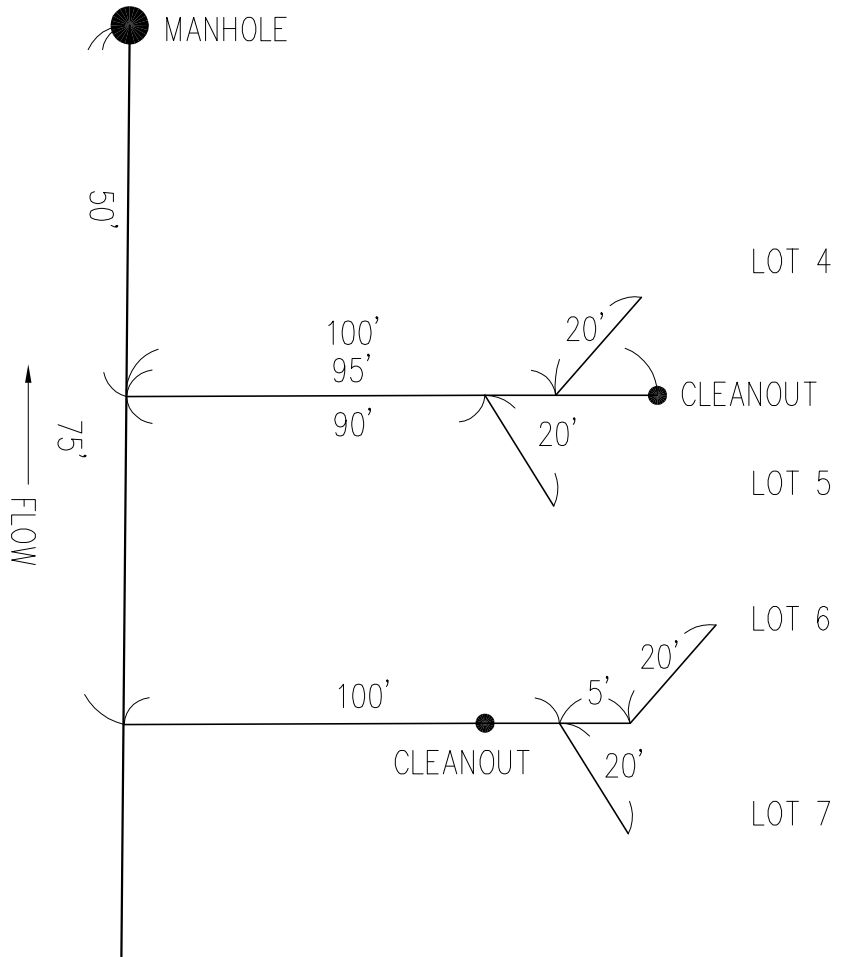

COMMON LATERAL DETAIL

NO SCALE

EXHIBIT A